

Photographs are indicative only, and may contain elements not supplied in kit.

Construction Guide

Attached Skillion (Flat Roof) Patio
Attached Skillion Awning
with a Rear Receiver Channel



Contents

1. Disclaimer	2	11. Making a stiffened gutter.....	14
2. General notes before using this guide.....	3	12. Fitting of post.....	15
3. Glossary of terms.....	4	13. Fitting of checked post	15
4. Component assembly diagram.....	5	14. Attaching to a slab	16
5. Components.....	6-8	15. Post into footing.....	16
6. Getting started.....	9	16. Fitting FLATDEK® roof sheets.....	17
7. Structure types.....	10	17. Fitting FLATDEK® light panels.....	17
8. Fitting attachment brackets and rear receiver channel.....	11	18. Fitting gutter straps.....	18
9. Fitting a headbeam.....	12	19. Prepare downpipe positions.....	19
10. Fitting reurn beam - rafter - purlin.....	13	20. Clean up.....	20

1. Disclaimer

IMPORTANT DISCLAIMER ABOUT THIS CONSTRUCTION GUIDE

IMPORTANT NOTE: This document is to be used in conjunction with the plans, drawings and specifications generated by the software CcBuilder for your specific job.

Date of Issue 2 September 2009

This guide is Version 001 issued on 2 September 2009. Lysaght Building Solutions Pty Ltd (LBS), may make changes to this guide in their sole discretion. You should check you are using the most up-to-date version of this guide before you start construction. Up to date construction guides are available by phoning 1800 80 81 82.

Conditions of Use

By using this guide, you acknowledge and agree that your use is subject to the terms and conditions in this guide. BlueScope Lysaght, its agents, officers, employees, subcontractors or consultants makes no representations, either expressed or implied, as to the suitability of the information and data in this guide for your particular purposes. It is your responsibility to ensure the design you use, the products you have purchased, your site and structural limitations and your building and construction capabilities are appropriate for your needs.

Use of Genuine Materials

Structures in this guide should only be built or constructed using those recommended genuine Lysaght products or approved third party products. Except as otherwise provide in these terms, any warranties only apply to you (if at all) if you use the recommended genuine LYSAGHT products or approved third party products and method of construction, recommended in this guide.

Check Delivery

It is important that you check all materials delivered to site against your bill of materials before you use them in your building or construction to ensure all components have arrived, are of the appropriate quality and are ready for installation.

Limitation of Liability

By using this guide, you accept the risks and responsibility and LBS will not be under or incur any liability to you (except to the extent which liability may not be lawfully excluded or limited) for, all losses, damages, costs and other consequences resulting directly or indirectly from using this guide, (including, without limitation, consequential loss or damage such as loss and profit or anticipated profit, loss of use damage to goodwill and loss due to delay) To the maximum extent permitted by law, LBS liability (whether arising under statute, contract, tort (including negligence), equity or otherwise) to any persons whatsoever in respect of anything done or not done, arising directly or indirectly, by any such person in reliance, whether in whole or in part, on this guide, is limited, at LBS's option, to:

- in the case of goods, the repair of the goods, the replacement of the goods or paying for the cost of repair or replacement of the goods; or
- in the case of services, the resupply of services or paying for the cost of resupplying the services

Warning

Failure to display the 'No foot traffic' safety sign on the roof will void your warranty.

2. General notes to be read before using this guide

This guide has been prepared for a range of designs using LYSAGHT products.

The information in this guide is suitable for use only in areas N1 (W28) - N3 (W41), and where a tropical cyclone is **unlikely** to occur as defined in Australian Standard AS4055 Wind Loads on Housing.

Lysaght Living Collection® kits have been designed as a complete unit.

All construction and connection details shall be made in accordance with the relevant standard connection detail drawings contained in this Guide and as generated by the software (CcBuilder) for your specific job.

For all structures in this guide the following notes apply

- These designs use LYSAGHT FLATDEK® roof profile and FIRMLOK® beams.
- The design allows for the structure to be attached on 1 side.
- The design is for attachment to timber framed structures only.
- The design allows for attachment to metal or timber fascia, timber cladding or brickwork
- Skillion designs incorporate a rear receiver channel for attaching to existing structure.
- Post height must not exceed 3000mm from ground level to underside of beam.
- The roof structure is designed for NO FOOT TRAFFIC.

Before you commence construction:

- (a) We recommended you obtain professional advice to ensure your particular needs are adequately met.
- (b) You should check with your local government authority to see if any form of prior permission or approval is required. It is your responsibility to obtain all necessary approvals.
- (c) If you want to build or construct any attached structure such as those covered by this Guide, you should seek advice from a suitably qualified engineer to verify the capacity of your existing structure to withstand any additional load arising from the proposed structure. You should also check with your local government authority to determine any specific requirements for the attachment to your existing structures.
- (d) You should check with your local workplace health and safety authority to see what safety measures you need to put in place prior to and during construction. It is the responsibility of the installer/erector to ensure all local safe work practices are adhered to and the safety of the whole site is maintained at all times.

Maintenance guide

To ensure maximum lifespan of your structure, consult the maintenance guide for information regarding maintenance, handling, storage and any other technical assistance you may require.

The maintenance guide is available from the following web site www.lysaght.com

3. Glossary of terms

BARGE CAP

Fixed to the roof where it meets with the return beam on projection sides.

CONCRETE FOOTING The concrete base to the post which anchors the structure against wind uplift.

CORE DRILLED FOOTING

When an existing concrete slab does not meet engineering requirements, a core is drilled through the slab to allow a concrete footing to be poured under the slab and around a post.

FRONT GUTTER

Carries water to the downpipe.

GUTTER STIFFENER

Fits inside projection gutter when more than 3000mm in length or inside front gutter when used as roof support (no headbeam).

HEADBEAM

Using FIRMLOK® beams, the headbeam supports the roof sheet on the projection end of the structure and is used when an eave (overhang) is required.

LIGHT PANEL

As it is a similar profile as the steel roofing, it can be fitted between the metal roof sheets to provide a source of light where required.

POST CONNECTOR (BASE)

An internal connector that attaches the post to the concrete slab with a screw anchor.

PROJECTION GUTTER

Side gutters which run with the roof fall. If more than 3000mm, will require gutter stiffener.

PURLIN

Attaches to rafter/return beam with connectors to carry roof sheets.

RAFTER ATTACHMENT

They are screwed to the existing rafter/truss and provide a fixing point for the receiver channel to attach to.

RECEIVER CHANNEL

Channel which is attached to the existing structure via rafter attachment brackets or direct to wall.

RETURN BEAM

Perimeter beam on projection side which can support purlins. They are attached to the fascia/wall via connectors.

TEK®

A self drilling screw for metal used to join components together.

4. Component assembly diagram

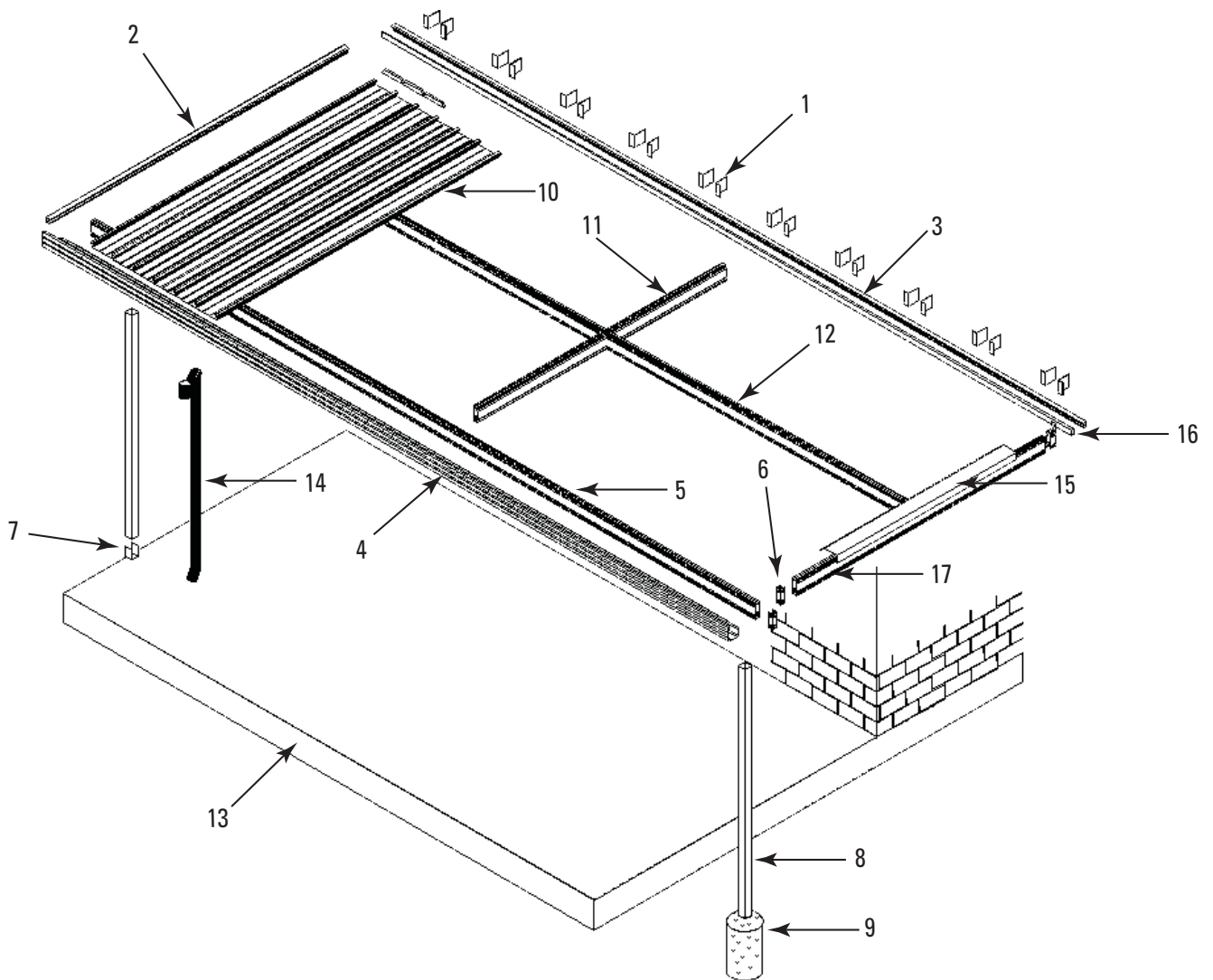
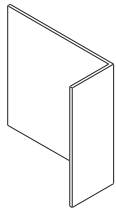

Figure 1

1. Rafter attachment bracket
2. Receiver channel as side capping
3. Receiver channel (rear)
4. Front gutter
5. Headbeam
6. Beam connector
7. Post bracket
8. Post
9. Footing
10. Roof sheeting
11. Rafter
12. Purlin
13. Concrete slab
14. Downpipe
15. Barge capping
16. Receiver channel foam
17. Return beam

5. Components



Rafter Attachment Bracket (CON110)

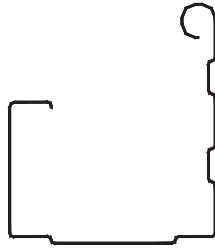

Sheerline Gutter (GS) (NSW/Vic)

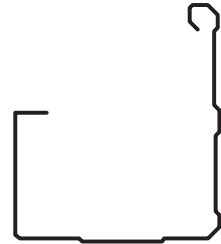

Fitfast Gutter (GSQ/GSSQ) (Qld)

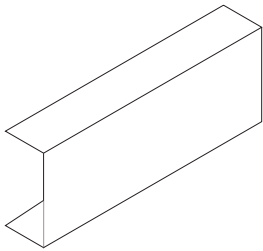

Gutter Stiffener (STUD19)

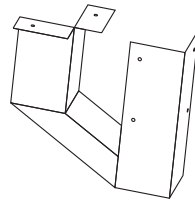

Gutter Corner (EXG) (Vic, NSW, Qld)



Quad gutter (GQ) (SA, Vic, NSW, Qld)

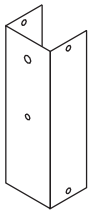

Beam Connector (CONB100/150/200)

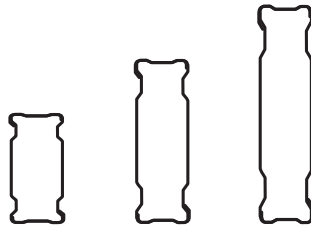

Firmlok Beams (BS100/150/200)

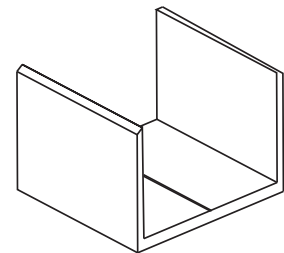

Aluminium Post Bottom Connector (CON50/60/75/90)

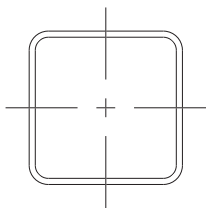

**Aluminum Post (PA50/75/90)
Steel Post (PS50/60/75/90)**

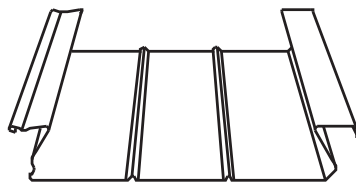

FLATDEK Roof Sheet (RS5)



FLATDEK Fibreglass Light Panel (RFG5)

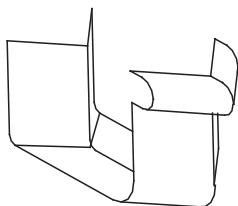

Quad gutter corner (QEC) (SA, Vic, NSW, Qld)

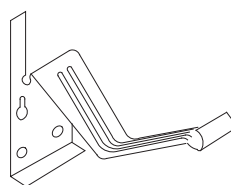

Quad gutter bracket (QIGPB) (SA, Vic, NSW, Qld)

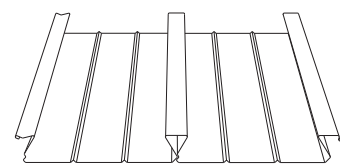

FLATDEK II (Qld only- RF5Q)

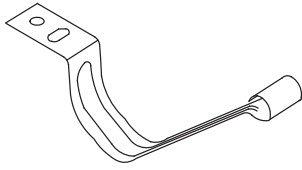

Quad gutter bracket (QOSHF)
(SA, Vic, NSW, Qld)



Barge capping
(SA, Vic, NSW, Qld)

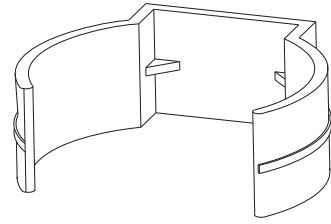

Downpipe strap
(DP65S/80S)



PVC Downpipe (DP65/80)

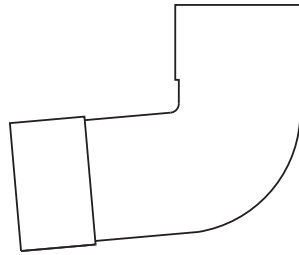

PVC Elbow (EL6590/8090)

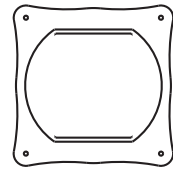

PVC Outlet (OL65/80)

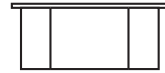

Gutter strap (STRAP20)



Silicone (SILIC)



Steel Downpipe
(DP10050/75)



Metal outlet
(OL10075/50)

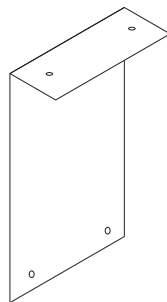

Post Face Bracket
(PBP75/90)



Downpipe strap steel
(AS10075/50)

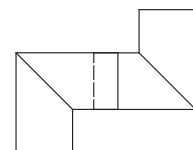

Offset
(ELOS10075/50)

5. Components

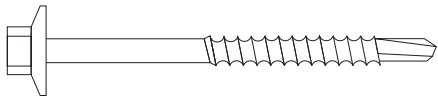

**Metal Tek® screw
(FT65M/FT45M)**

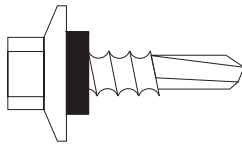

**Metal Tek® screw
with washer (FT20MN)**

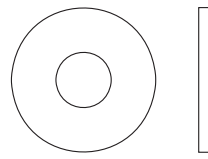

**Metal Washer
(WASH8)**

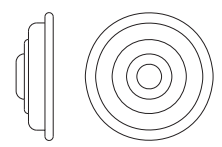

**Washer for
fibreglass (WGFG)**



**4.0mm Rivet
(FR64)**



**3.2mm Rivet
(FR72)**



**Long 4.0mm
Rivet (FR80)**

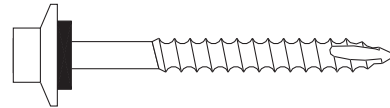

**Timber Tek® screw
(FT50T)**

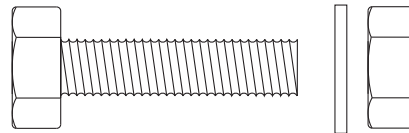

**Nut, hex head bolt and
washer (FBH20)**

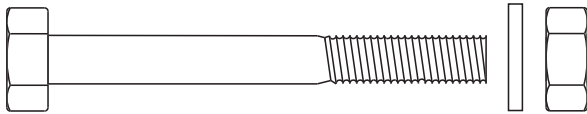

**Nut, hex head bolt and washer
(FBH30, FBH50, FBH60)**

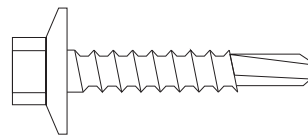

**Metal Tek® screw
(FT30M)**

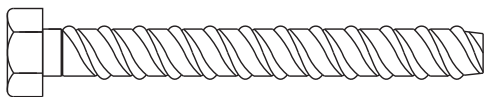

**Screw anchor (SA7510G,
SA1008G)**

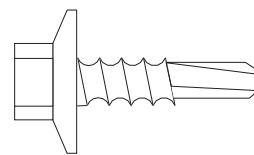

**Metal Tek® screw
(FT20M)**

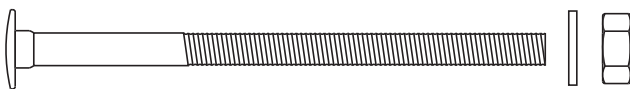

**Nut, Cup head bolt and
washer (FBC110)**

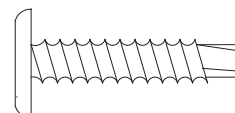

**Wafer head screw
(FHW22)**



Roof sign

6. Getting started

Please read the following instructions carefully before starting the project.

Suggested tools

Ladders
Plank
Saw horses
Adjustable stands
Spirit level
Electric drill (battery operated) and drill bits
Angle grinder
Electric lead
Personal safety equipment
Pop rivet gun
Socket set
String line
Assortment of hand tools

Site preparation

Firstly prepare the work area for the construction so it is safe and easy to work in.

Clear work area of obstacles and debris.

Unpack the kit and crosscheck all the components against the Bill of Materials. This should be done adjacent to the work area.

If there is a discrepancy between what you have received and the Bill of Materials, please contact the store where purchased immediately and prior to commencement of work.

7. Structure types

Skillion structures (Attached 1 side)

1. Roof is supported on the outer edge with a head beam and can have an eave overhang. (Not available in SA) (Figure 2)

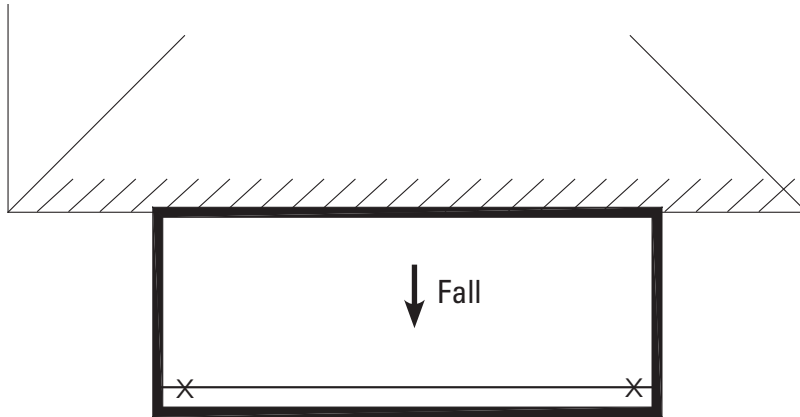

Structure 1: Head Beam

Figure 2

When setting out against fascia/wall, the start and finish of the job will depend on the type of end options that have been chosen.

Whether using gutter, barge cap or reciver channel as the finish to the side of the project - measurements are taken from outside to outside.

8. Fitting attachment brackets and rear receiver channel

You will need

RAFTER ATTACHMENT BRACKETS

RECEIVER CHANNEL

FIXINGS

Prior to fixing in position, remove plastic film and apply silicone to the face which is to be attached. The silicone should be applied in a w-pattern approximately 10mm wide.

Once fixed in position, apply a bead to the top join where it meets the fascia/wall.

Position the receiver channel to the existing fascia, below existing gutter. (Figure 3)

Make sure the channel is level and using Tekes, screw to the fascia. This will allow the rafter / truss attachment brackets to be set in the correct position.

Wearing gloves, push up the bottom row of roof tiles or unscrew the roof sheets to allow access to the existing rafter/truss. Fit the rafter attachment brackets with the large face sitting up against the rafter/truss tail and the small face hard up against the back of the existing fascia. The bracket can sit on top of the eave sheet, but do not apply downward pressure as this will bow the eave sheets.

Connect the brackets to the truss using timber Tekes at 1200 spacing's for 600mm spaced rafters or 900 spacing's for 450mm spaced rafters. Note: Drill holes in timber rafter with a 6mm drill bit to avoid splitting the rafter if necessary, starting from the corners. For connection details, refer to CcBuilder engineering drawings.

With the receiver channel in position, drill a 10mm hole through the back edge of the receiver channel, existing gutter, fascia and attachment bracket and fit a nut and bolt.

Fitting receiver channel to wall/brickwork

(See Cc Builder drawings for specific details for attaching to walls. After cutting to length, hold in position and mark fixing points on receiver channel. Pre-drill holes where fixings will pass through the channel. Remove plastic film and apply silicone using method previously detailed.

NOTE: If using a return beam or rafter, fit blocking channel as per drawing from Cc Builder. Fit connector with extension leg as per drawing (See section 10: Fitting a return beam, rafter, purlin).

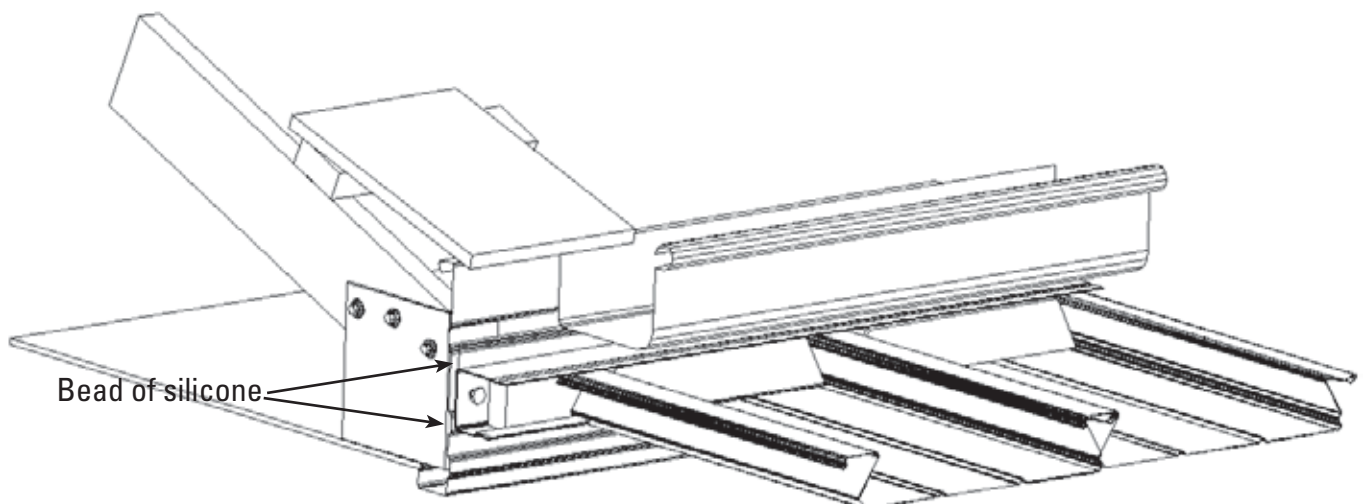

Figure 3

9. Fitting a headbeam

YOU WILL NEED:

BEAM

BEAM CONNECTORS

FIXINGS

To support the headbeam, position stands for both height and projection. Cut beam to required length and peel back plastic film from both ends.

If attaching rafters or return beams, fit required connectors as per Cc Builder drawing. Remember these brackets will have to line up with the positioning of the blocking channel.

For easy fitting of beams into connectors, measure from outside to outside of beam connectors, mark beam and deduct 10mm and cut. This will allow the beam to be fitted into the connectors with ease.

With the horizontal seam of the beam to the top and facing out lift the beam into the connectors, square off the connectors to beam and support while fixing off with Tekes®.

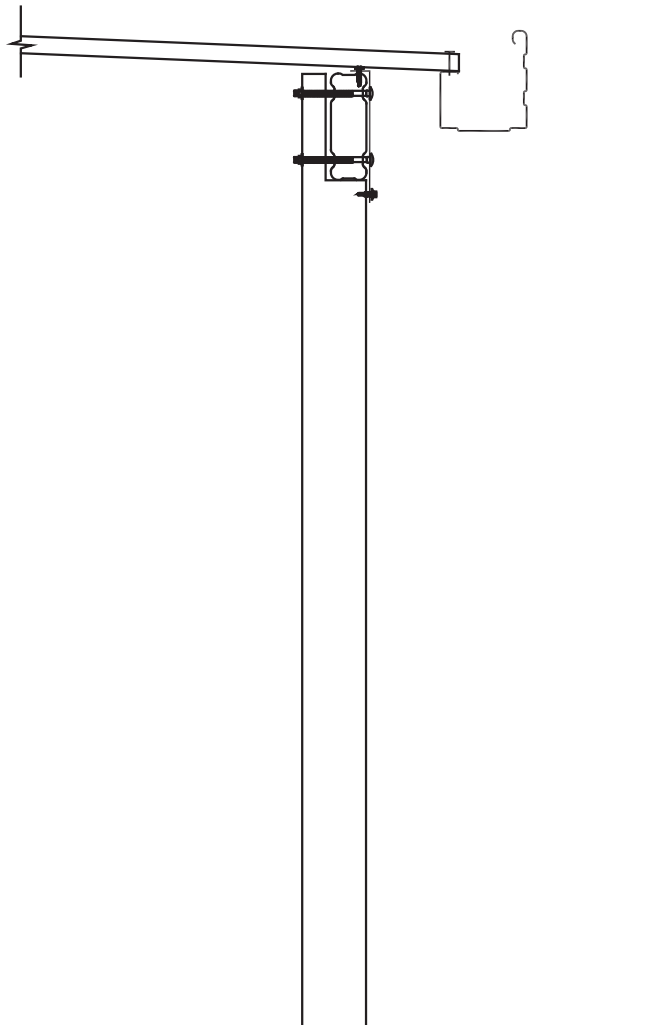

10. Fitting return beam - rafter - purlin

YOU WILL NEED:

BEAMS

BEAM CONNECTORS

FIXINGS

If the structure requires a purlin, or a return beam, a rafter may need to be installed.

Note:

A return beam-purlin-rafter can be of a smaller dimension to the headbeam.

Fix connections per drawing (Figure 4) where the purlin fits into a return beam. This is the typical connection where a purlin attaches to a rafter. See the CcBuilder drawings for the details of beam to beam and beam to rafter connections. (Figure 5)

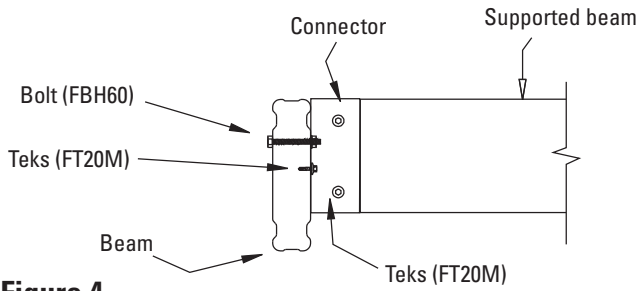

Figure 4

Fascia blocking for point loads on receiver channels

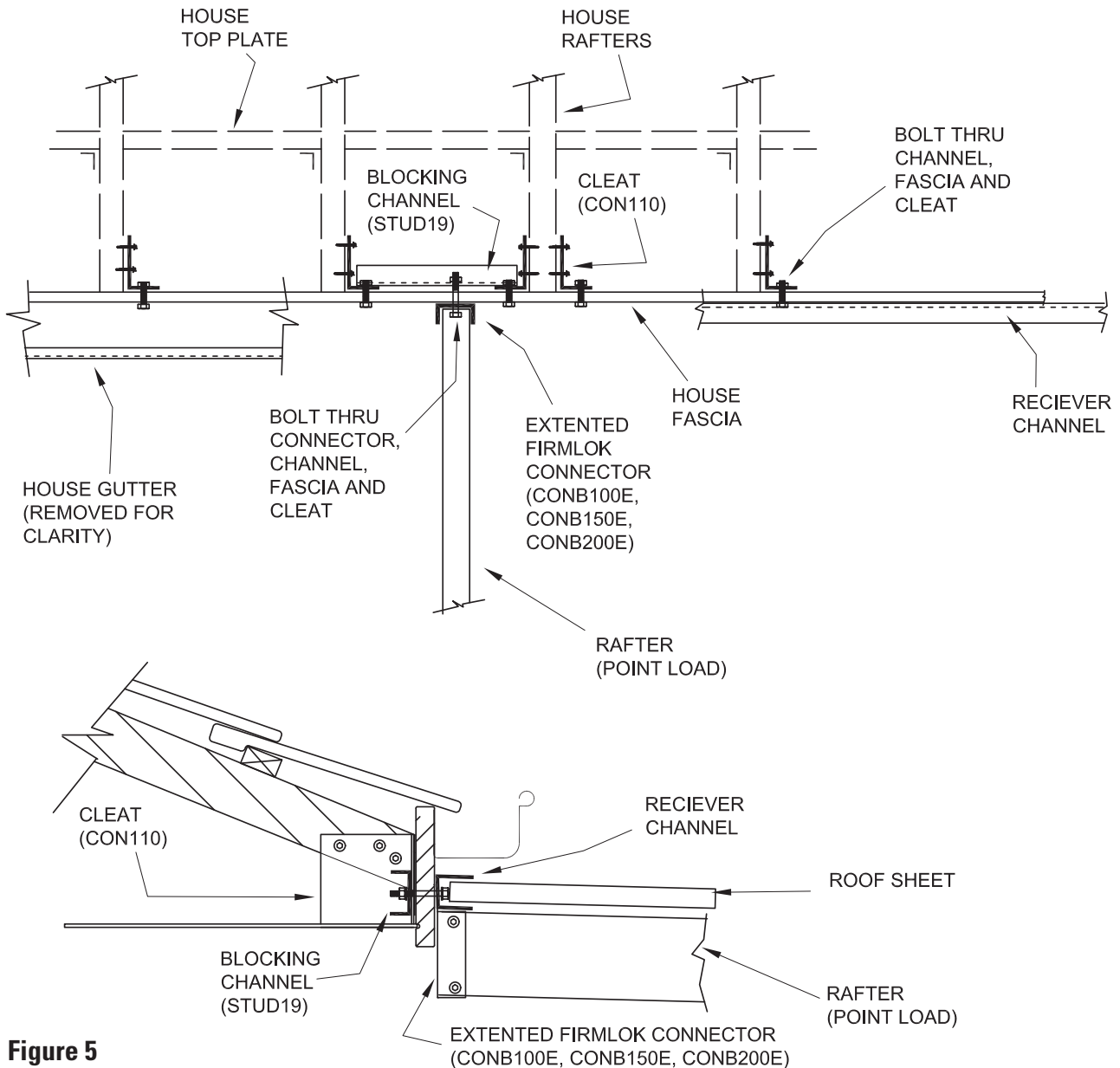

Figure 5

11. Making a stiffened gutter

YOU WILL NEED:

GUTTER

GUTTER STIFFENER (Attached structures only)

GUTTER CORNERS (if using gutter on projection side)

FIXINGS

To make a stiffened gutter, a stiffener (Stud 19) is required to be fitted to the gutter in the following circumstances:

When projection gutter (side) is more than 3000mm, and no return beam is required.

Measure the internal of the gutter from corner to corner and cut stiffener to size. Subtract 2mm for clearance.

Fit stud stiffener into gutters using rivets at 600mm spacings. At corners, fix off using nut and bolt to one side and a rivet to other as per drawing. (Figure 6)

If fitting gutter corners or end caps, see Cc Builder drawings for details.

Note: Fit stiffener into gutter before fitting gutter corner.

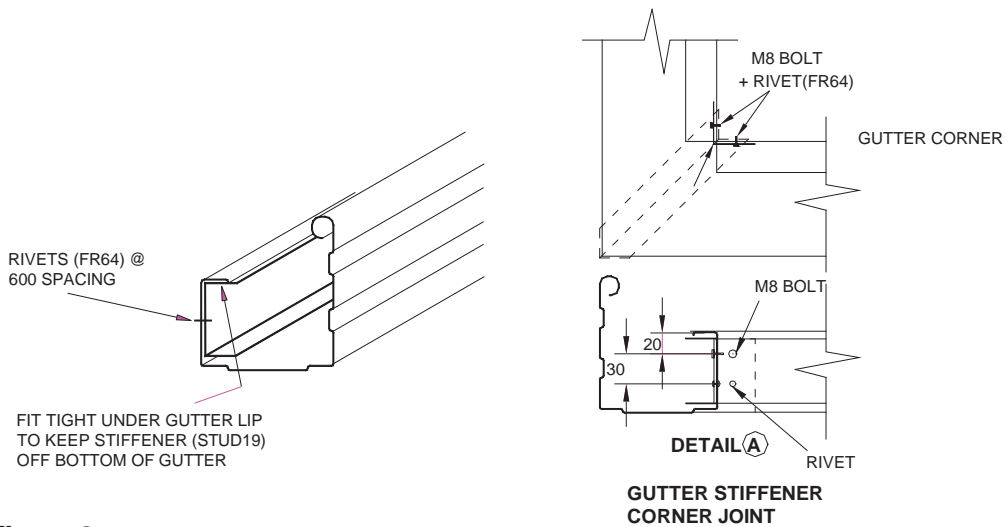

Figure 6

12. Fitting of post (behind headbeam)

Check CcBuilder Plan for post positions and details for maximum span between posts.

YOU WILL NEED:

POSTS

NUTS AND BOLTS

BOTTOM POST CONNECTORS SLAB ONLY

TEKS

The posts will be bolted to the back of the beam as per drawing. With the headbeam supported by stands/props and fixed to the connectors, string a line across the face of the beam and adjust props to make level. (Figure 7)

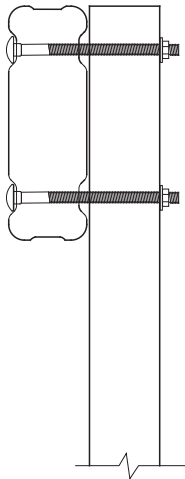

Figure 7

13. Fitting of checked post

Check CcBuilder Plan for post positions and details for maximum span between posts.

Fit posts into position using clamps. Fit bracket plate to face of post and beam and screw off in position. (Figure 8)

Using the holes in the post as a template, drill through the post bracket and once plumb and positioned, fix off as per drawing.

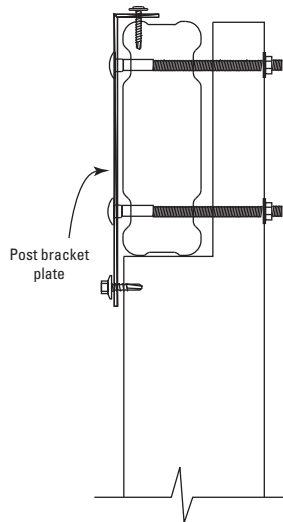

Figure 8

14. Attaching to a slab

The following method can be used for all post sizes. For correct fixing details, refer to drawing.

Ascertain the position of the posts along the beam, measure from the top of the beam down to concrete slab.

Place the post on supports and cut to length.

Clamp post in correct plumb position. Mark position on slab and mark at top on beam.

Using the internal post connector as a template, mark the holes on the slab and drill holes to the required depth.

Blow the dust out of the hole using either mechanical means or otherwise and attach the connector to the slab using the supplied screw anchor. Place some silicone around the hole for waterproofing.

Place the post over the bottom connector and position at top. Plumb and clamp off ready for fixing. (Figure 9)

Fix top of post as appropriate per previous Sections (14-16).

Fit bolts and tighten with nuts. Attach with fixings at the base.

This type of fixing is for attached structures only. Refer to engineering details for freestanding models.

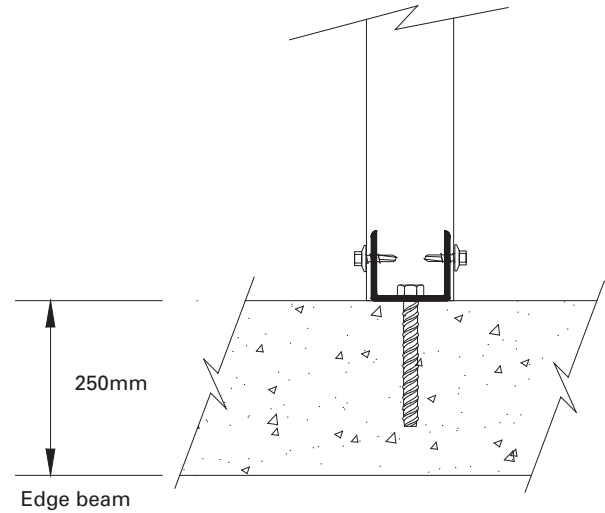

Figure 9

15. Post into footing

The top attachment is done per the previous section.

Ascertain the position of the post on the beam, plumb down and mark position on ground.

Check depth and width of footing from Engineers detail, and remove soil.

Measure from bottom of hole to under side of beam, deduct 100mm and cut to length.

Prepare bottom of post as per Engineering detail.

Place post in hole, clamp off at top while fitting the bolts and tighten with nuts.

Mix concrete as per manufacturers instructions and pour into holes whilst checking for plumb. (Figure 10a & 10b show optional core drilled hole into existing slab or a new footing)

NOTE: Seal all penetrations, corners and top edge of attached gutters with silicone and leave overnight or until cured. NOTE: Working on structure before concrete is cured will affect rigidity.

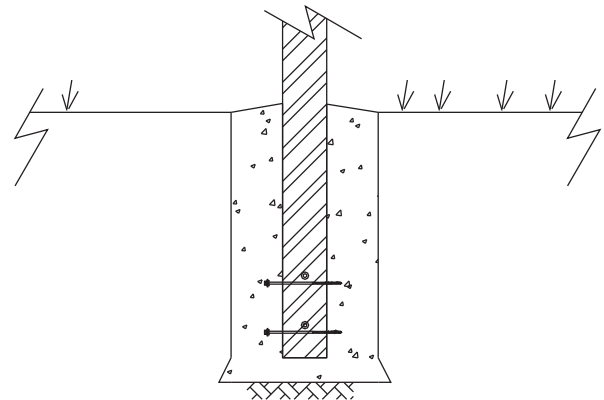

Figure 10a

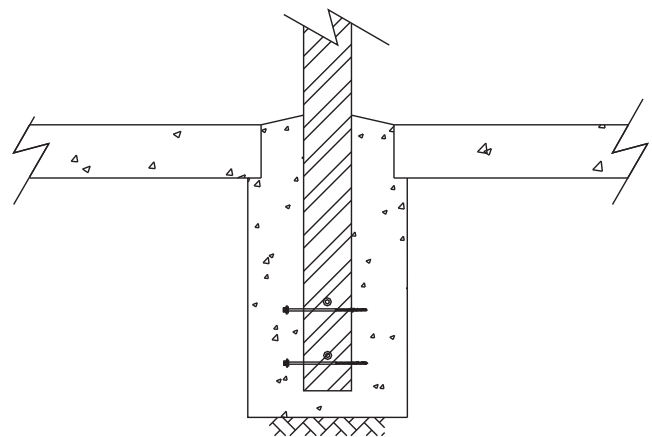

Figure 10b

16. Fitting Flatdek

Note: Read the following carefully as it is difficult to separate sheets.

Fit foam strip into length of receiver channel. Remove protective plastic from underside of sheet and fit first sheet into channel with male side facing outwards. Once square to structure, push sheet hard into foam and fix off as per Cc Builder drawings.

Laying next sheet as per diagram, fit sheet up to opening of channel and clip together as shown in diagram for about 100mm.

Using a block of wood, hammer other end of sheet into rear receiver and grasping the next sheet with 2 gloved hands, position sheet over top of preceding sheet. Using the heel of your hands, perform a rolling motion away from you at the same time applying pressure downwards as per diagram. (Figure 11)

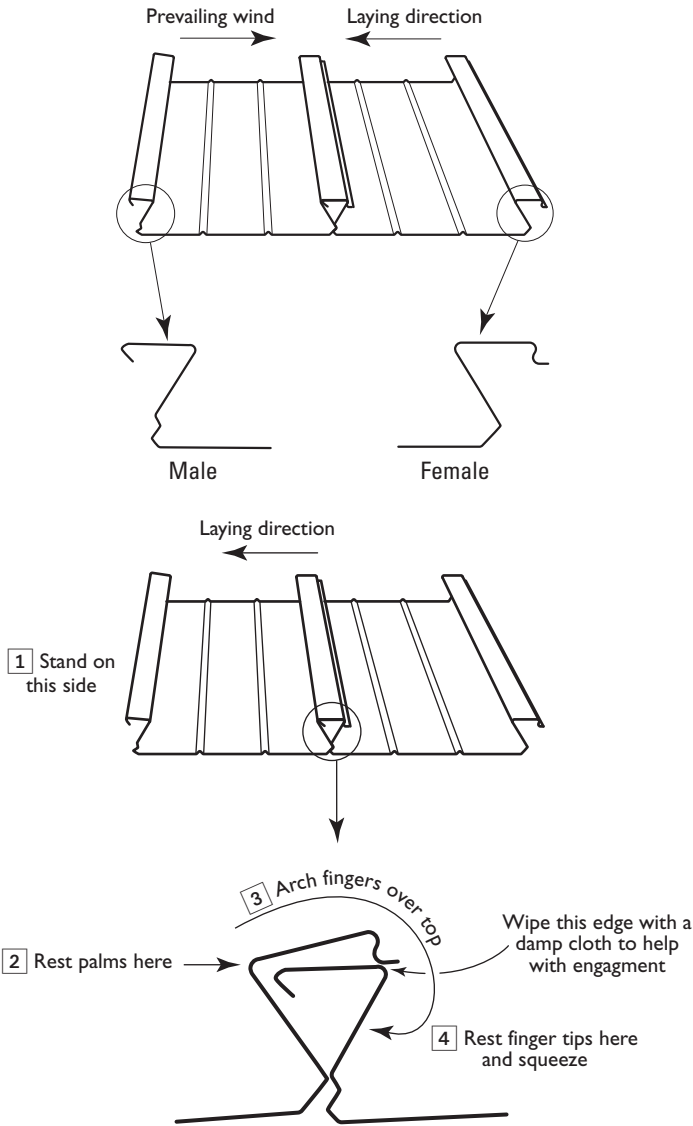

Figure 11

17. Fitting Flatdek light panels

A light panel must be fitted at least 2 steel sheets in from any side and must have 2 steel sheets separating them.

Unlike the steel panels, both sides of a light panel fits over the male and female sides.

Working from a projection side, fit a minimum of 2 steel panels first and fix off.

Lay the light panel in position. Do not fix off. Next to that, place a steel sheet in under the light panel

The light panel should be sitting over the top of 2 steel sheets. Once position is correct, fix off steel sheet first and then light panel as shown below. (Figure 12)

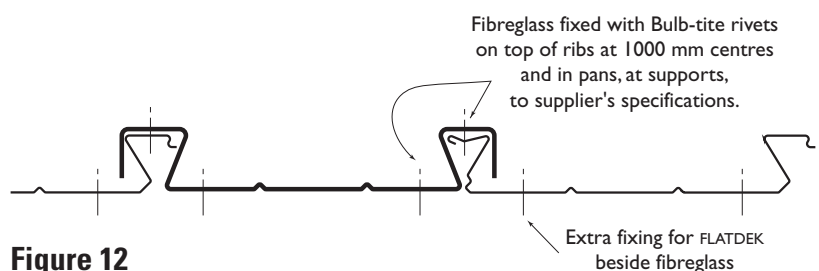

Figure 12

18. Fitting gutter straps

On completion of roof, string line projection wet gutters to check for straightness.

Fix off gutter strap using Tek® screws as Figure 15 for side gutter and Figure 16 for front gutter as per drawings.

Alternatively, fix off to beams as shown in Figures 13-16.

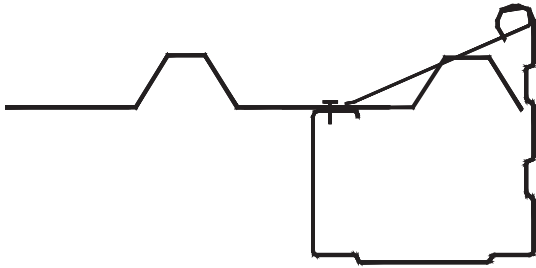

Figure 13

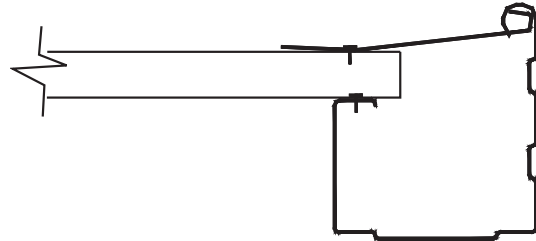

Figure 14

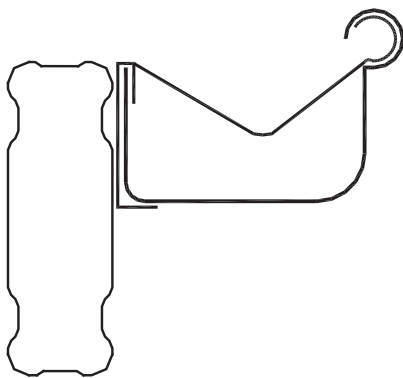

Figure 15

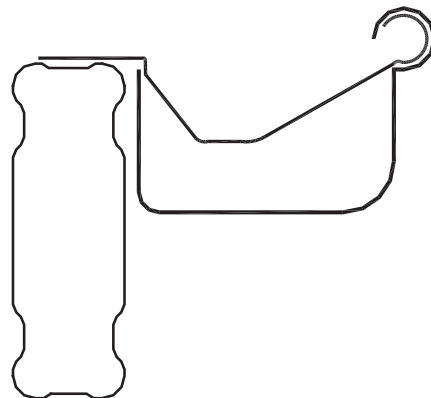

Figure 16

19. Prepare downpipe position

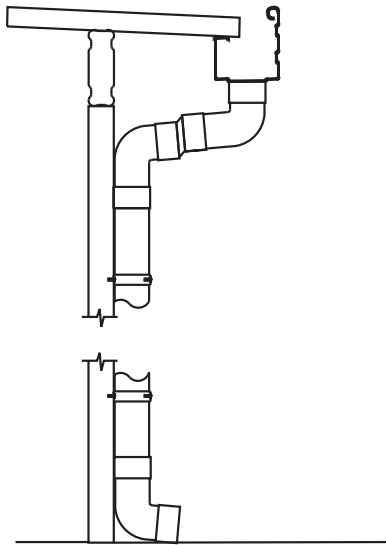

Figure 17

YOU WILL NEED

DOWNPIPE

OUTLET

DOWNPIPE STRAP

DOWNPIPE ELBOW

RIVETS

Place downpipe outlet on bottom side of front gutter in required position and mark the internal shape of the outlet onto the gutter.

Drill a pilot hole in bottom of gutter and then remove with snips. This can be done when preparing front gutter.

For PVC, rivet outlet to outside bottom edge of gutter where required and silicone seal.

Fix downpipe straps to the post with 1 rivet.

Fit supplied downpipe together using silicone to join connections. (Figures 17-18 - Example shown for overhang only for both round and square downpipes.)

Fix off as per CcBuilder drawings.

For steel fit outlet to inside of gutter and push down until outlet is sitting flat with bottom of gutter. Turn gutter over and fix to the bottom of the gutter using rivets and silicone sealant.

20. Clean up instructions

On completion remove all foreign objects from all the surfaces

e.g. Swarf (drilling debris) packaging, rubber ,etc.
Attention should be made to the rear gutter, with all foreign material hosed completely out of all gutters. This is generally done using a hose and broom.

Please download the maintenance guide from:

www.lysaght.com

Congratulations

Your new structure is now ready to use.

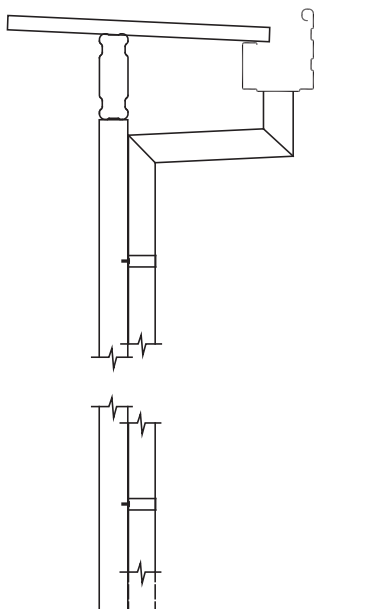

Figure 18



Disclaimer, warranties and limitation of liability

This publication is intended to be an aid for all trades and professionals involved with specifying and installing LYSAGHT products and not to be a substitute for professional judgement.

Terms and conditions of sale available at local BlueScope Lysaght sales offices.

Except to the extent to which liability may not lawfully be excluded or limited, BlueScope Steel Limited will not be under or incur any liability to you for any direct or indirect loss or damage (including, without limitation, consequential loss or damage such as loss of profit or anticipated profit, loss of use, damage to goodwill and loss due to delay) however caused (including, without, limitation, breach of contract, negligence and/or breach of statute), which you may suffer or incur in connection with this publication.

© Copyright BlueScope Steel Limited 24 January, 2011

Discuss availability of design options with your
LYSAGHT Living Collection Dealer.

www.lysaghtlivingcollection.com

LYSAGHT Living Collection®, TRIMDEK®, FLATDEK®, COLORBOND® AND ZINCALUME® are registered trademarks of BlueScope Steel Limited, ABN 16 000 011 058. The LYSAGHT® range of products is made by or for BlueScope Steel Limited trading as BlueScope Lysaght. Lysaght Building Solutions is a wholly owned subsidiary of BlueScope Steel Limited. 24 January 2011

Colorbond®

**BLUESCOPE
LYSAGHT**

