

Construction Guide

Designer Patio
Designer Awning



Contents

1. Disclaimer	2	17. Fitting off the posts.....	16
2. General notes before using this guide.....	3	18. Attaching to a slab	17
3. Glossary of terms.....	4	19. Post into footing.....	17
4. Component assembly diagram.....	5	20. Making gable end trusses.....	18
5. Components.....	6-8	21. Making intermediate trusses.....	19
6. Construction guide	9	22. Fitting the rail/rafter connector.....	20
7. Starting your project	10	23. Fitting the purlin connector.....	20
8. Rafter attachment brackets	11	24a. Fitting FLATDEK roof sheets	21
9. Gutter	12	24b. Fitting TRIMDEK roof sheets	21
10. Fitting a gutter stiffener	12	25a. Fitting FLATDEK light panels.....	22
11. Obstructions	13	25b. Fitting TRIMDEK light panels.....	22
12. Fitting the front gutter	13	26. Fitting of flashings	23
13. Beam and rail layout using rafters/beams/purlins	14	27. Prepare downpipes.....	24
14. Headbeam.....	14	28. Clean up instructions	25
15. Rails (Gable insert supports)	15	NOTES.....	26
16. Return beam - purlin	15		

1. Disclaimer

IMPORTANT DISCLAIMER ABOUT THIS CONSTRUCTION GUIDE

IMPORTANT NOTE: This document is to be used in conjunction with the plans, drawings and specifications generated by the software CcBuilder for your specific job.

Date of Issue 30 May 2009

This guide is Version 001 issued on 30 May 2009. Lysaght Building Solutions Pty Ltd (LBS), may make changes to this guide in their sole discretion. You should check you are using the most up-to-date version of this guide before you start construction. Up to date construction guides are available by phoning 1800 641 417.

Conditions of Use

By using this guide, you acknowledge and agree that your use is subject to the terms and conditions in this guide. LBS, its agents, officers, employees, subcontractors or consultants makes no representations, either expressed or implied, as to the suitability of the information and data in this guide for your particular purposes. It is your responsibility to ensure the design you use, the products you have purchased, your site and structural limitations and your building and construction capabilities are appropriate for your needs.

Use of Genuine Materials

Structures in this guide should only be built or constructed using those recommended genuine LYSAGHT® products or approved third party products. Except as otherwise provide in these terms, any warranties only apply to you (if at all) if you use the recommended genuine LYSAGHT products or approved third party products and method of construction, recommended in this guide.

Check Delivery

It is important that you check all materials delivered to site against your bill of materials before you use them in your building or construction to ensure all components have arrived, are of the appropriate quality and are ready for installation.

Limitation of Liability

By using this guide, you accept the risks and responsibility and LBS will not be under or incur any liability to you (except to the extent which liability may not be lawfully excluded or limited) for, all losses, damages, costs and other consequences resulting directly or indirectly from using this guide, (including, without limitation, consequential loss or damage such as loss and profit or anticipated profit, loss of use damage to goodwill and loss due to delay) To the maximum extent permitted by law, LBS liability (whether arising under statute, contract, tort (including negligence), equity or otherwise) to any persons whatsoever in respect of anything done or not done, arising directly or indirectly, by any such person in reliance, whether in whole or in part, on this guide, is limited, at LBS's option, to:

- in the case of goods, the repair of the goods, the replacement of the goods or paying for the cost of repair or replacement of the goods; or
- in the case of services, the resupply of services or paying for the cost of resupplying the services

Warning

Failure to display the 'No foot traffic' safety sign on the roof will void your warranty.

2. General notes to be read before using this guide

This Guide has been prepared for a range of designs using LYSAGHT products.

The information in this guide is suitable for use only in areas N1 (W28) - N3 (W41), and where a tropical cyclone is **unlikely** to occur as defined in Australian Standard AS4055 Wind Loads on Housing.

Lysaght Living Collection® kits have been designed as a complete unit.

All erection and connection details to be made in accordance with the relevant standard connection details drawing contained in this Guide.

For all structures in this Guide:

- These designs use CUSTOM ORB®, TRIMDEK®, FLATDEK®, SPANDEK® roofing profiles and FIRMLOK® beams.
- The design allows for the patio cover to be attached on 1 side only or Freestanding.
- The design is for attachment to timber frame structure only.
- The design allows for attachment to metal/timber fascia only.
- Post height must not exceed 2700 mm from ground.
- Roof pitch of structures are preset at 22.5 degrees.

Before you commence construction:

- (a) We recommended you obtain professional advice to ensure your particular needs are adequately met.
- (b) You should check with your local government authority to see if any form of prior permission or approval is required. It is your responsibility to obtain all necessary approvals.
- (c) If you want to build or construct any attached structure (such as those covered by this Guide), you should seek advice from a suitably qualified engineer to verify the capacity of your existing structure to withstand any additional load arising from the attached structure. You should also check with your local government authority to determine any specific requirements for the attachment to existing structures.
- (d) You should check with your local workplace health and safety authority to see what safety measures you need to put in place prior to and during construction. It is the responsibility of the installer/erector to ensure all local safe work practices are adhered to and the safety of the whole site is maintained at all times.

Maintenance guide

To ensure maximum lifespan of your structure, consult the maintenance guide for information regarding maintenance, handling, storage and any other technical assistance you may require.

The maintenance guide is available from the following web site www.lysaght.com

3. Glossary of terms

ATTACHMENT GUTTER

Rear gutter attached to the existing house fascia with Z brackets that are fixed through to the attachment brackets.

BARGE CAPPING

Fixes to the gable end of the structure where the roof sheets start and finish.

CONCRETE FOOTING

Required when not attaching to a slab (See engineers detail)

CORE DRILLED FOOTING

When an existing concrete slab does not meet engineers standard, a core is drilled from the slab to allow a footing to be poured under the slab and around a post.

CRESTWOOD

Structure which employs the gable insert style of roof.

CROWN CONNECTOR

Used at the top of a gable end and intermediate truss where a rafter and ridge purlin intersect.

DOWNPIPE

Carries water away from the gutter and is usually fitted to a post and then connected directly into a storm water system.

FRONT GUTTER

Attaches to the projection gutters and carries water to the downpipe.

GUTTER OUTLET

Sometimes referred to as the "drop", fitted to the front gutter and allows the water to drain into the downpipe.

GUTTER STIFFENER

Fits inside attachment gutter at rear to support return beams, rafters and beams that carry the insert (Side rails).

HEADBEAM FIRMLOK®

Supports side rails, rafters and return beams. Also supports roof sheeting and guttering at front.

LIGHT PANEL (POLYCARBONATE and FIBREGLASS)

Replaces steel roofing where extra light is required.

POST

The design uses 90/75 aluminum/steel posts, pre-checked for fitment to the headbeam.

POST CONNECTOR (BASE)

Is attached to a concrete slab with a screw anchor and fits inside the post. The post is attached to the connector with Tek's.

POST BRACKET

Is attached to the junction of the post and beam and prevents the two from coming apart under load.

PROJECTION GUTTER

Side gutters which run and fall with the roof projection.

PURLIN (Insert) FIRMLOK® BS100

Runs at 90 degrees to rafters and supports roof sheets. Attaches to a crown connector at the ridge and mid-span on a rafter.

PURLIN (Skillion section) FIRMLOK® BS100-150-200

Attaches to rafters and return beams at 90 degrees. Supports roof sheets midway through span.

RAFTER (Insert) FIRMLOK® BS100

Spans between a crown connector at the top of the structure and a beam/side rail. Also supports purlins.

RAFTER CONNECTOR RRC10 (Insert)

Connects a rafter at the intersection of a side rail.

RAFTER (Skillion) FIRMLOK® BS100-150-200

Runs parallel with roof sheets to support purlins. Is attached with connectors to headbeams and attached gutters.

RAFTER CONNECTOR CONB100-150-200 (Skillion)

Connects rafters to headbeams and rear attached gutters.

RAFTER ATTACHMENT

Attached to the existing house rafter/truss and provide a fixing point for the Z brackets to attach.

RAIL FIRMLOK® BS150-200

Supports the gable insert structure. Is fixed to the headbeam and rear attached gutter with connectors.

RETURN BEAM FIRMLOK® BS100-150-200

Used where a purlin is required to support a roof span and is attached to a headbeam at front and attached gutter, at rear. Also supports side gutters. (Projection)

RIDGE CAPPING

Fixes to the ridge of structure and waterproofs the roof sheets where they meet.

ROOF SHEET (CUSTOM ORB®, TRIMDEK®, SPANDEK®, FLATDEK®)

Fixes to headbeams, gutters and purlins.

Z BRACKET

Fits inside the rear gutter and connects the structure to the existing house rafter/truss via the attachment bracket.

4. Component Assembly Diagram

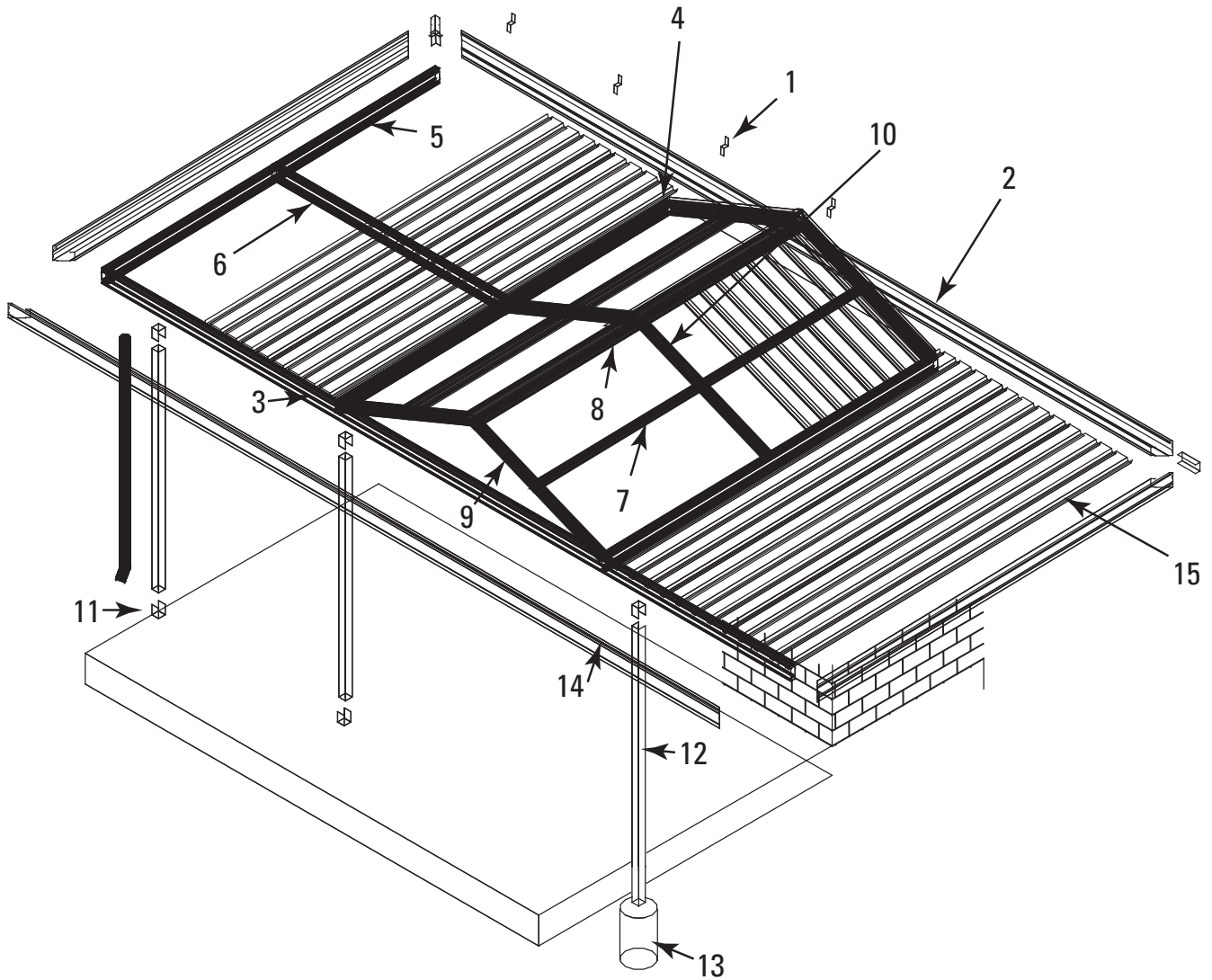
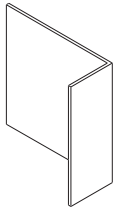

Figure 1

1. Rafter attachment bracket
2. Attached rear gutter
3. Headbeam
4. Rail
5. Return beam
6. Purlin
7. Mid purlin
8. Ridge purlin
9. Gable end truss
10. Intermediate truss
11. Bottom internal connector for slab
12. Post
13. Concrete footing
14. Downpipe
15. Roof sheeting

5. Components



Rafter Attachment Bracket (CON110)

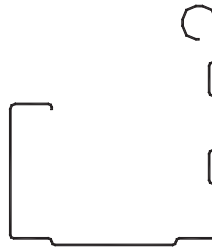

Sheerline Gutter (GS)

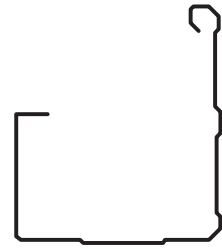

Fitfast Gutter (GSQ/GSSQ)

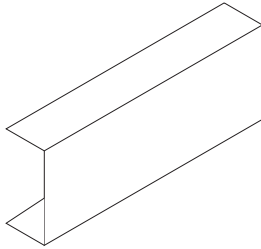

Gutter Stiffener (STUD19)

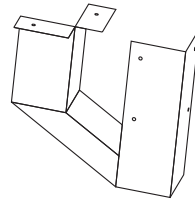

Gutter Corner (EXG)

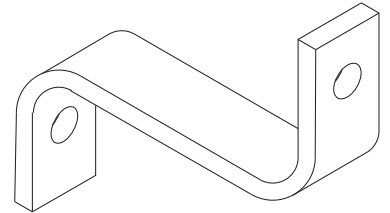

Steel Z Bracket (ZGS)

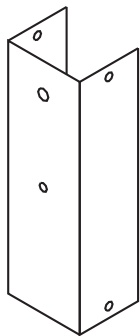

Purlin/Crown Connector (CONB100)

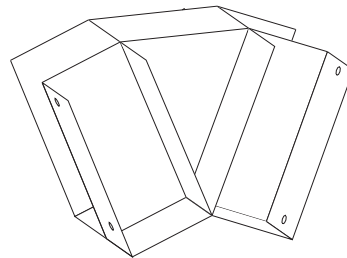

Gable End Crown Connector (CC10)

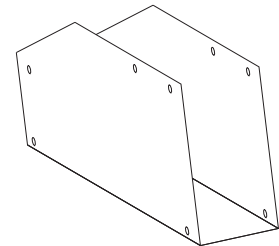

Collar Tie (CTC10)

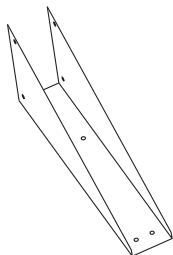

Rafter/Rail Connector (GRBC10)

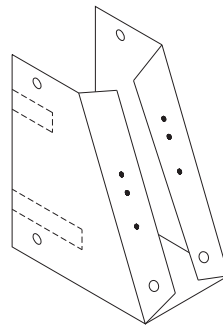

Rafter/Side Rail Connector (RRC10)

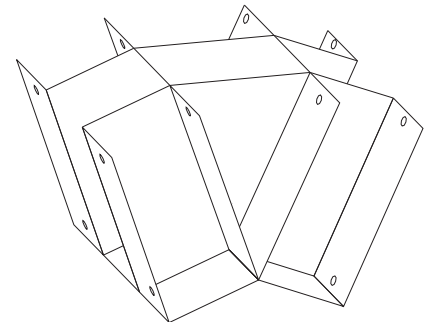

Intermediate Crown Connector (CCD10)

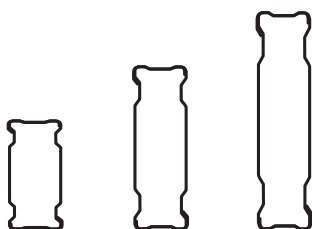

Firmlok Beam (BS100/150/200)

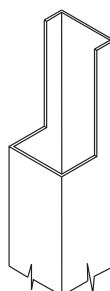

**Aluminum Post (PS/PA90N150/200)
(PS/PA75N150/200)**

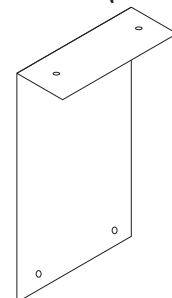

**Post Face Bracket (PBP75/150/200)
(PBP90/150/200)**

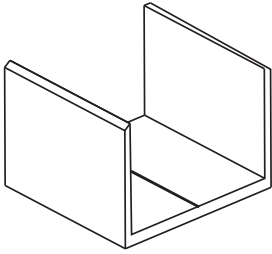

Aluminium Bottom Connector (CON75/90)

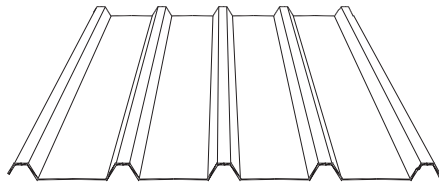

Fibreglass or polycarbonate Lightpanel (RS2PC)

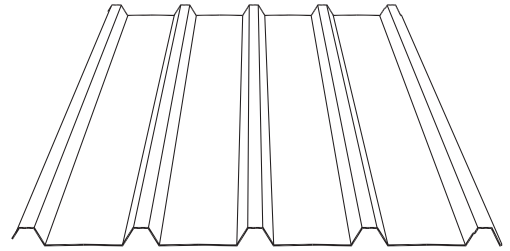

Trimdek (RS2)

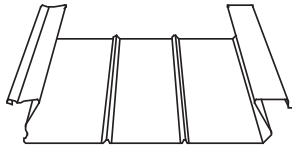

Flatdek Roof Sheet (RS5)

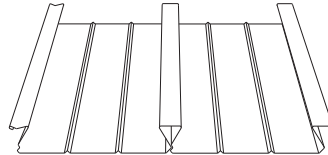

Flatdek II Qld only (RS5Q)



Fibreglass Light Panel (RS5FG)

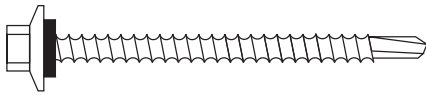

Metal Tek® screw (FT65/75M)

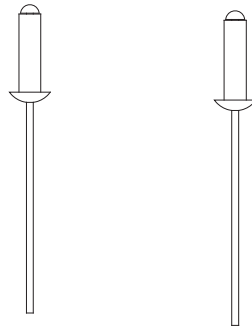

4.0mm Rivet (FR64)

3.2mm Rivet (FR72)

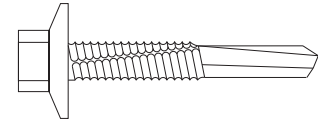

Metal Tek® screw (FT32MS)

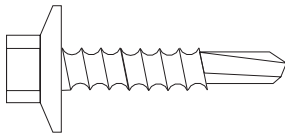

Metal Tek® (FT16M)

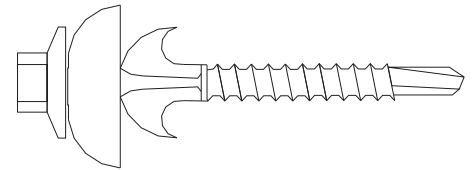

WingedTek (FT50/65MP)

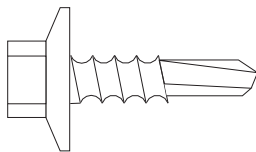

Metal Tek® screw (FT20M)

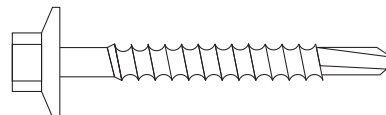

Metal Tek® (FT45M)

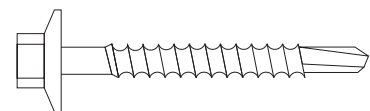

Metal Tek® screw (FT45M)

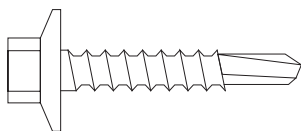

Metal Tek® screw (FT30M)

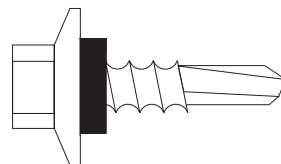

Metal Tek® screw with washer (FT20MN)

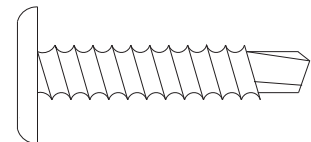

Metal Tek (FWH22)

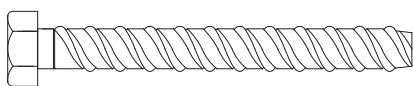

Screw Anchor (SA1008G)

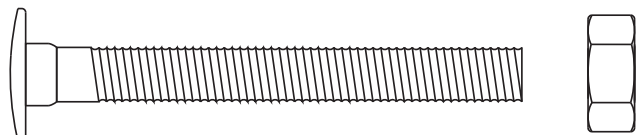

Nut, Cup head bolt and washer (FBC60/70/90)

5. Components (cont.)

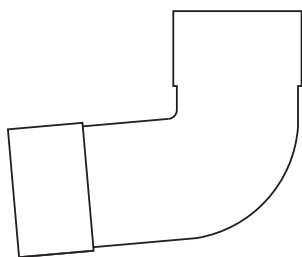

PVC Elbow (EL6590/8090)

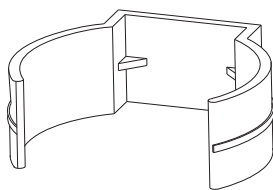

Downpipe strap (DP65S/80S)

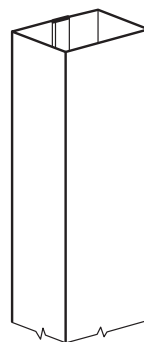

Steel Downpipe DP100x50/75

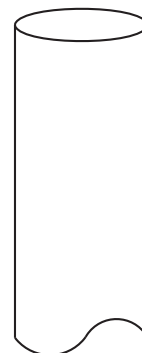

PVC Downpipe (DP65/80)



Atragal (AS10075/10050)

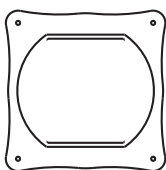

PVC Outlet (OL65/80)

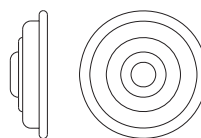

Washer for fibreglass (WG)

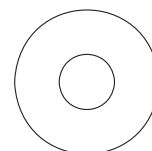

Metal Washer (WASH8)

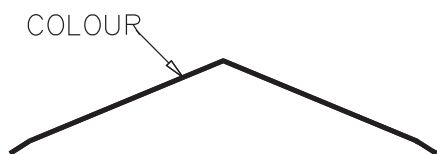

Ridge Capping (RC2)

ALL CORNERS 90° U.O.N.



Barge Capping (GB3)



Silicone (SILIC)



Roof sign

6. Construction guide

Please read the following instructions carefully before starting the project.

Suggested tools

Ladder
Plank
Saw horses
Stands
Spirit level
Drill and drill bits
Angle Grinder
Electric lead
Gloves and Safety glasses
Pop rivet gun
Assortment of hand tools
Socket Set

Site preparation

Firstly prepare the work area for the construction so it is safe and easy to work in.

Clear work area of obstacles and debris.

Unpack the kit and crosscheck all the components against the Bill of Materials. This should be done adjacent to the work area.

If there is a discrepancy between what you have received and the Bill of Materials, please contact the store where purchased immediately and prior to commencement of work.

7. Starting your project

Gable inserts

A Gable insert, is a Skillion structure with a gable inserted into the frame. They can only be attached to an existing structure, however - not freestanding.

This model has perimeter gutter to all sides, headbeam at front and "rails" for the insert to sit on.

These rails sit slightly higher than the headbeam as detailed later in this guide.

When the projection of the structure exceeds the chosen roof profiles span, a mid purlin will be provided.

To carry the purlin, a return beam will also be provided.

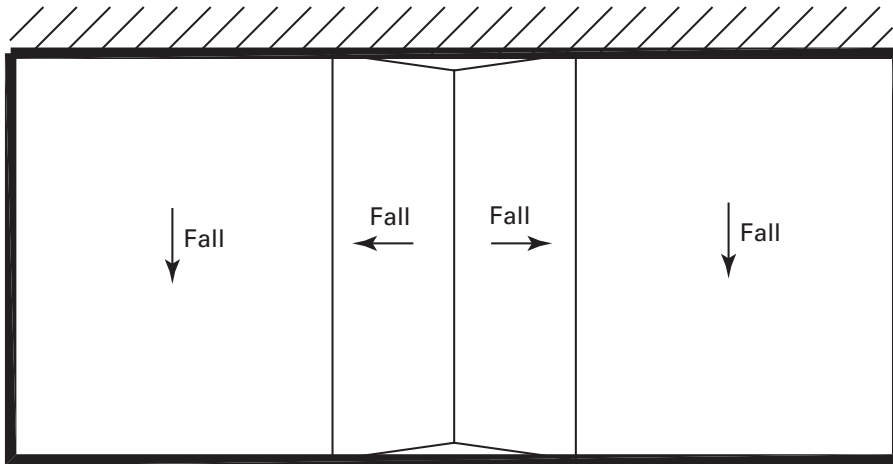

Figure 2: Attachment to structure

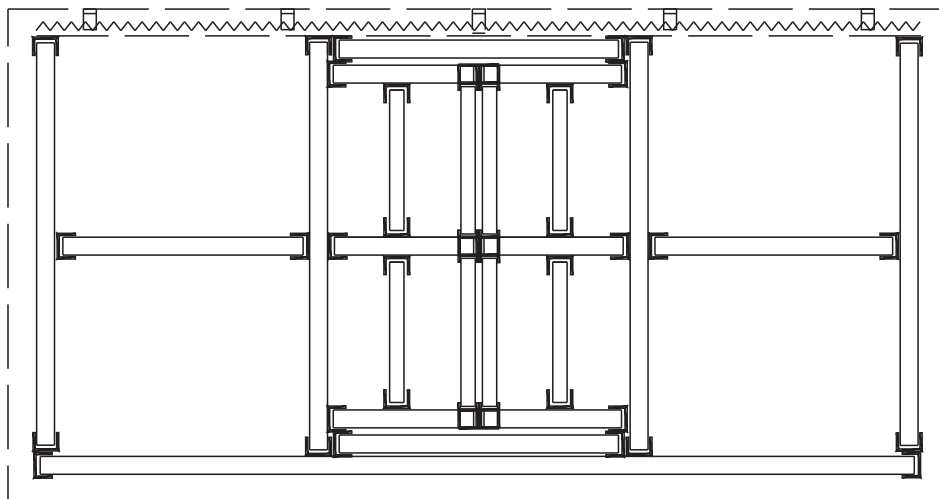

Figure 3: Plan of Beams

8. Rafter attachment brackets (timber rafters/trusses only)

YOU WILL NEED:

RAFTER ATTACHMENT BRACKETS

Z BRACKETS

FIXINGS

Position the prepared gutter with attached corner brackets to the existing fascia, 20mm below existing gutter.

Make sure the gutter is completely level and using teks, temporarily screw the gutter to the fascia. This will allow the rafter / truss attachment brackets to be set in the correct position. These teks will be removed later.

Wearing gloves, push up the bottom row of roof tiles or unscrew the roof sheets to allow access to the existing rafter/truss. Fit the rafter attachment brackets with the large face sitting up against the rafter/truss tail and the small face hard up against the back of the existing fascia. The bracket can sit on top of the eave sheet, but do not apply downward pressure as this will bow your soffit sheets.

Connect the brackets to the truss using timber teks at 1200 spacing's for 600mm spaced rafters or 900 spacing's for 450mm spaced rafters. Note: Drill holes in timber rafter with a 6mm drill bit to avoid splitting the rafter.

To attach the Z brackets, place the Z bracket inside the gutter with the long leg upwards against the inside edge, in line with the rafter attachment bracket.

Mark where the Z brackets are to go, drill a 10mm hole through the back edge of the gutter, fascia and attachment bracket and fit a nut and bolt

Fit a nut and bolt to the front face of the gutter, through the Z bracket.

You can now remove the small teks from the gutter that held it in place.

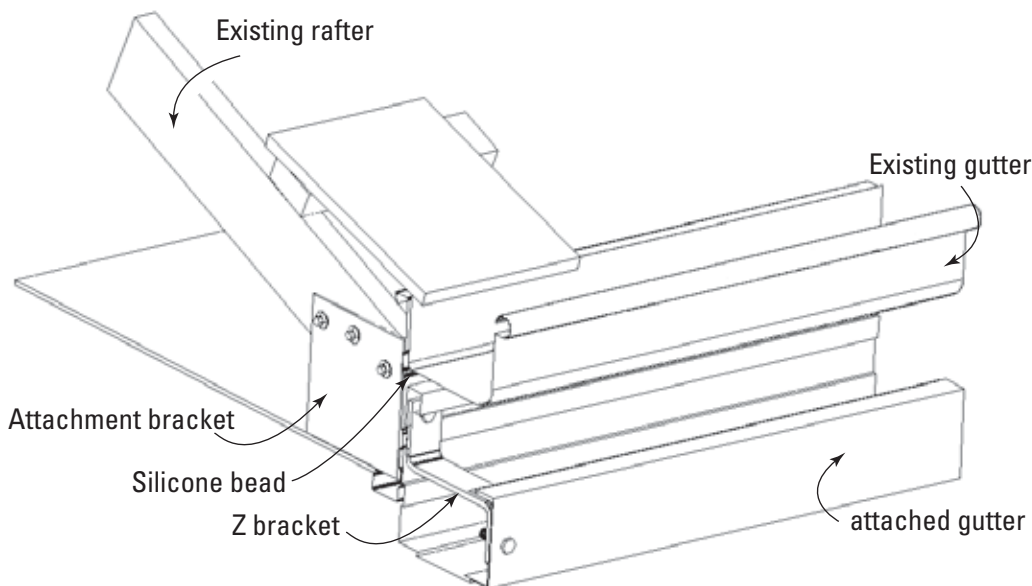

Figure 4: Finished view of attached gutter

9. Gutter

YOU WILL NEED:

GUTTER

GUTTER STIFFENER

GUTTER CORNERS

FIXINGS

Using a marker, mark the start and finishing points of the structure on your existing fascia. Remember the measurements are from outside of gutter bracket to outside of gutter bracket.

Transfer these points to the ground/slab for later use when positioning posts.

The design has gutter on all sides.

On supports, cut a 45 degree angle to one end of the gutter and fit a gutter corner as per drawing.

Checking the measurement on your plan, measure from the outer-most edge of the fitted gutter corner along to the desired length and mark. Using the gutter corner bracket, align the corner of the bracket over the mark and remark the gutter allowing for the bracket. If 6000mm is the plan length, then this will be from outside of gutter corner bracket to outside of gutter corner bracket at the other end.

Remove the plastic covering before fixing the gutter corner and attach the gutter corner with rivets.

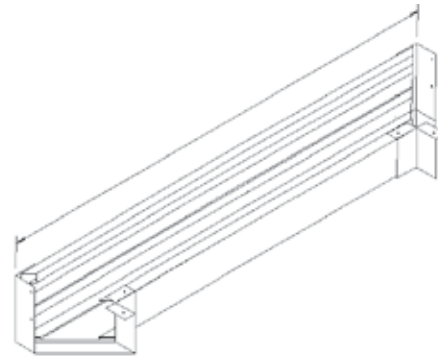

Figure 5: Gutter corner to gutter corner

10. Fitting a gutter stiffener

You need to fit a gutter stiffener to the gutter to be attached to the existing structure.

Measure the internal of the gutter from corner to corner and cut stiffener to size. Subtract 2mm for clearance.

Fit stud stiffener into gutters using rivets at 600mm spacings. At corners, fix off using nut and bolt to one side and a rivet to other as per engineering drawing.

Note

Fit stiffener into gutter before fitting gutter corner.

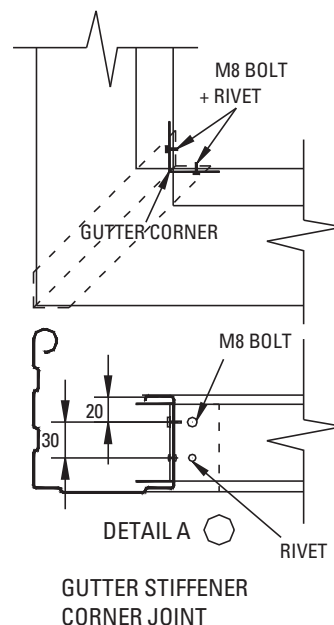
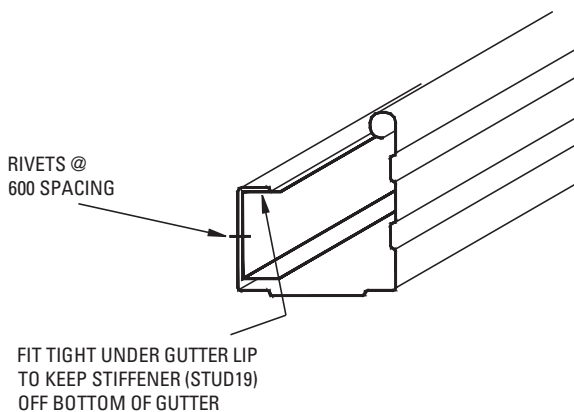

Figure 6: Gutter stiffener at corner

11. Obstructions

If there is an obstruction along a fascia, like a down pipe preventing you from attaching the gutter, remove the down pipe to expose a drop/outlet.

From a building supply centre, get some ALCORE and make a cone approximately 100 mm deep to fit over the drop. This will then sit in the new gutter when fitted.

Fit a new PVC outlet to the new gutter directly under the existing as per the detail and re-fit the original down pipe under the new gutter at a later stage.

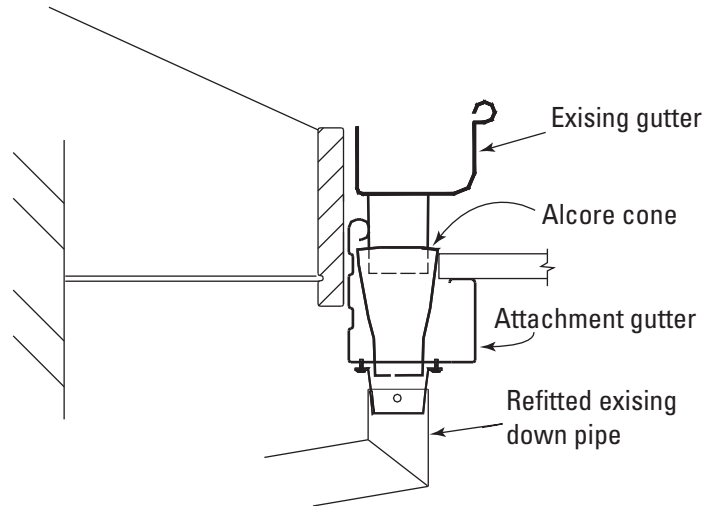

Figure 7: Gutter obstructions

12. Fitting the front gutter

YOU WILL NEED:

GUTTER

STUD STIFFENER

FIXINGS

At this point, 3 gutters will be standing with gutter corners attached.

Square structure by checking diagonals and adjusting the projection gutters in or out until diagonals are the same.

Re-measure rear gutter length, and cut both ends of gutter at 45 degrees, fit downpipe drop/outlet in desired position.

Prepare stands for gutter to sit on, lift gutter into alignment and slide one corner in at a time, back into gutter corners and fix off.

Repeat same for other end.

Temporarily brace structure, fix off gutter corners and check it is square and brace.

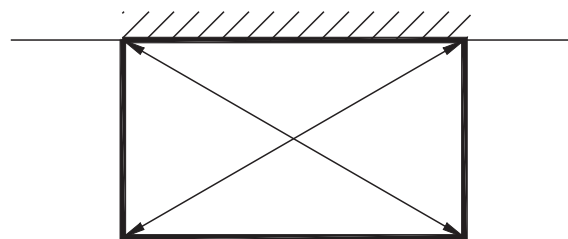

Figure 8: Fitting front gutter

13. Beam and rail layout using rafters, return beams and purlins

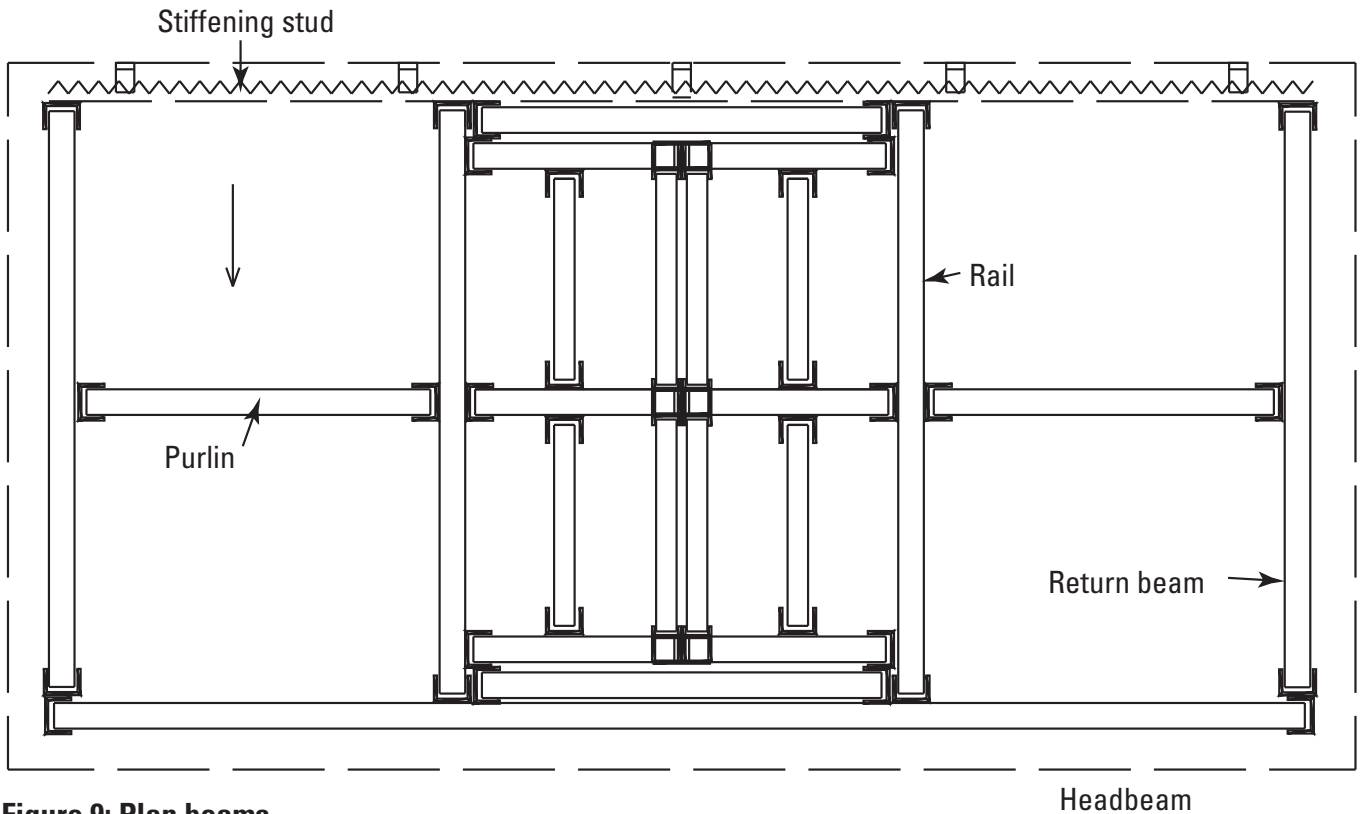

Figure 9: Plan beams

14. Headbeam

YOU WILL NEED:

BEAM

BEAM CONNECTORS

FIXINGS

Fit beam connectors CONB100/150/200 in required plumb position on both gutters as per engineering drawings.

For easy fitting of beam into connectors, measure from outside to outside of beam connectors, mark beam and deduct 10mm and cut. This will allow the beam to be fitted into the connectors with ease.

With the horizontal seam of the beam to the top and facing out lift the beam into the connectors, square off the connectors to beam and support while fixing off.

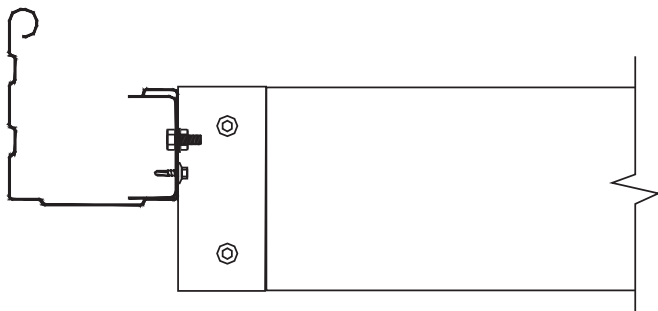

Figure 10: Headbeam

15. Rails (Gable insert supports)

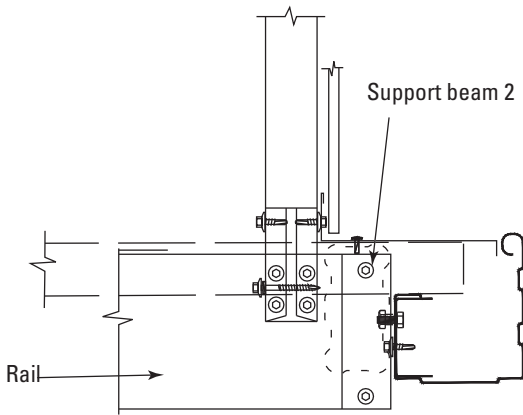

Figure 11: Support beam to rail

YOU WILL NEED:

BEAMS

BEAM CONNECTORS

FIXINGS

B1. Mark the overall position of the gable insert on the headbeam and corresponding attached gutter.

Attach connectors to the headbeam and the attached gutter as per drawings.

Allowing for the brackets, measure and cut the rails, fix in position as per drawings.

B2. A support beam is to be fitted in between the front and back rails up against the respective gutters. (See engineering drawing)

Measure the distance between the rails and deduct 10mm for easy fitment. Attach connectors either side and fit beam in from the top and fix off as per drawings.

16. Return beam - purlin

YOU WILL NEED:

BEAMS

BEAM CONNECTORS

FIXINGS

If the roof span requires a purlin (specified on the plan), a return beam will need to be fitted.

Attach a connector to the headbeam and to the rear attached gutter as per the drawings.

Note:

A return beam-purlin-rafter can be of a smaller dimension to the headbeam, due to engineering calculations.

For fitting purlins see engineering drawings.

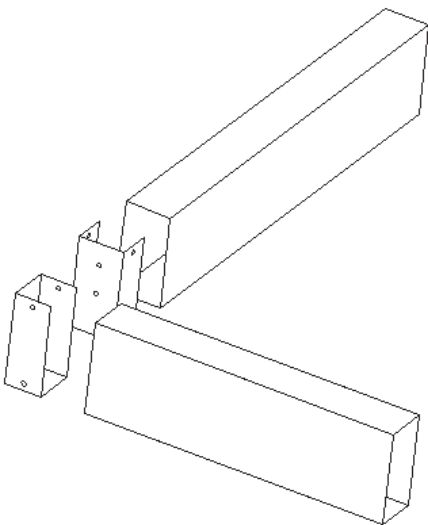

Figure 12: Coner connection between beams

17. Fixing off the posts

With posts in position and clamped, fit the Post Bracket Plate over the face of the post and fix off using wafer head screws through the top of the post and bracket and fix off into the post at the bottom of the bracket.

Using the predrilled holes in the post as a guide, drill 2 / 9mm holes through the beam/rail and the post bracket plate. (Figure 13)

Mix concrete as per manufacturers instructions and pour into holes while checking for plumb.

With posts in position and clamped, fit the Post Bracket Plate over the face of the post and fix off using wafer head screws through the top of the post and bracket and fix off into the post at the bottom of the bracket.

Using the predrilled holes in the post as a guide, drill 2 / 9mm holes through the beam/rail and the post bracket plate. (Figure 14)

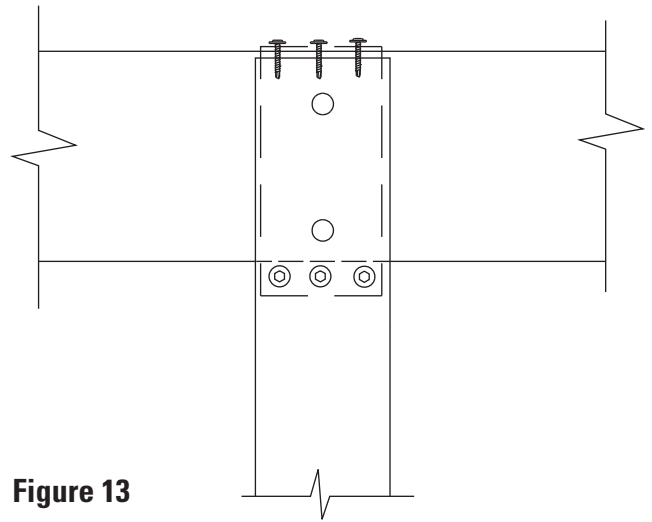

Figure 13

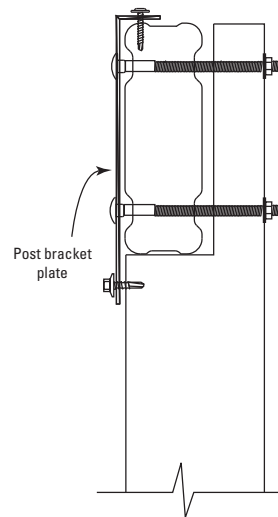

Figure 14

18. Attaching to a slab

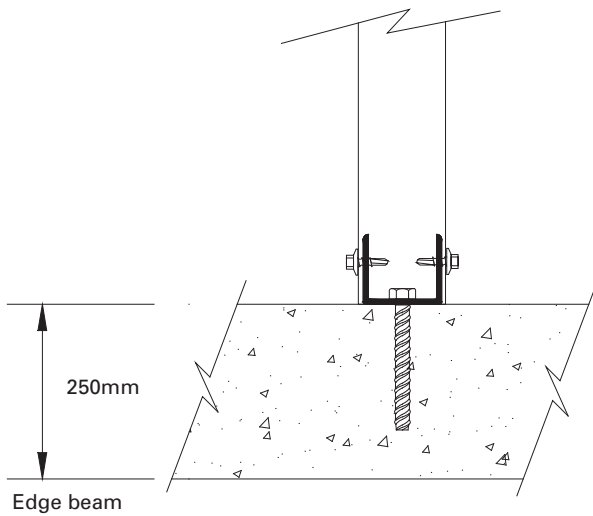

Figure 15

The following method can be used for all post sizes. For correct fixing details, refer to drawing.

Ascertain the position of the posts along the beam, measure from the top of the beam down to concrete slab.

Place the post on supports and cut to length.

Clamp post in correct plumb position. Mark position on slab and mark at top on beam.

Using the internal post connector as a template, mark the centre hole on the slab and drill hole to the required depth.

Blow the dust out of the hole using either mechanical means or otherwise and attach the connector to the slab using the supplied screw anchor.

Place the post over the bottom connector and position at top. Plumb and clamp off ready for fixing. (Figure 15)

Using the indentations of the FIRMLOK beam, drill holes through the beam and the post.

Fit bolts and tighten with nuts. Attach with fixings at the base.

Mix concrete as per manufacturers instructions and pour into holes while checking for plumb.

19. Post into footing

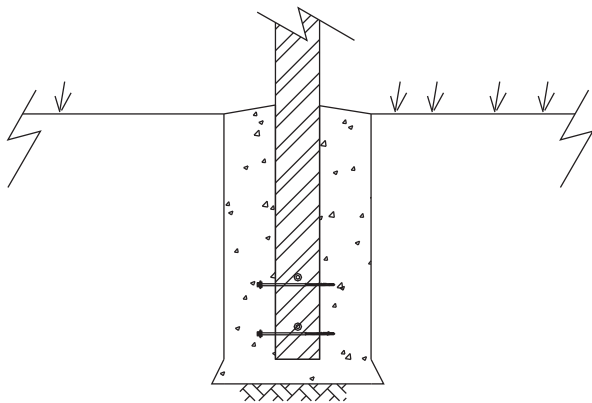

Figure 16a

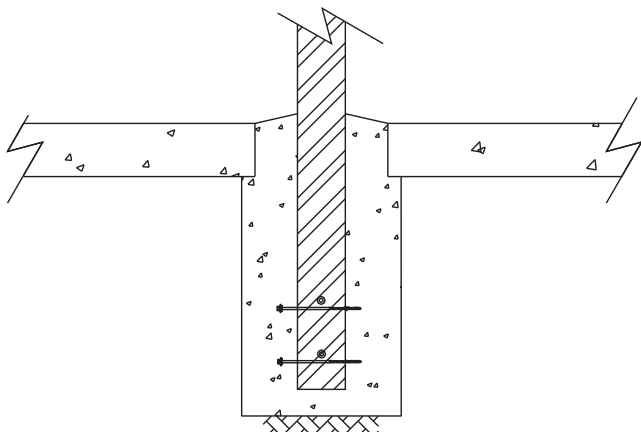

Figure 16b

The top attachment procedure is the same as fixing to a slab.

Ascertain the position of the post on the beam, plumb down and mark position on ground.

From Engineers detail, check depth and width of footing and remove soil.

Measure from bottom of hole to under side of beam, deduct 100mm and cut to length.

Prepare bottom of post as per Engineer detail.

Place post in hole, clamp off at top while fitting the bolts and tighten with nuts.

Mix concrete as per manufacturers instructions and pour into holes whilst checking for plumb. (Figure 16a & b show optional core drilled hole into existing slab or a new footing)

NOTE: Seal all penetrations, corners and top edge of attached gutters with silicone.

Leave overnight for curing.

20. Making gable end trusses

YOU WILL NEED

RAFTERS

CROWN CONNECTOR

PURLIN CONNECTORS

NUT AND BOLT

TEKS

NOTE: PREPARE TRUSSES ON THE GROUND

Note: For Gable end truss, only use connectors that are one sided.

Feed the rafters into the connector until the top edge of the rafter is just touching the leading edge of the connector and make sure the connector is square to the rafter on both sides. Clamp off square and fix.

With both rafters attached, drill a 9mm hole through the completed crown connector and rafter.

Repeat for other connector and fix off as per drawings.

Fit completed end gable truss to structure, house the rafter into the rail to rafter connector by approximately and fix off.

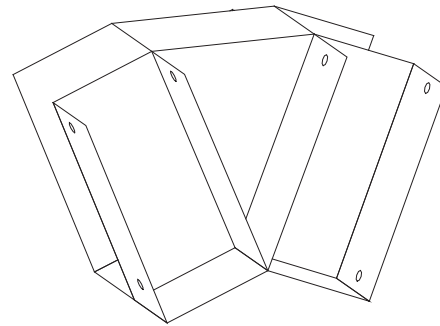

Figure 17: Gable end crown connector

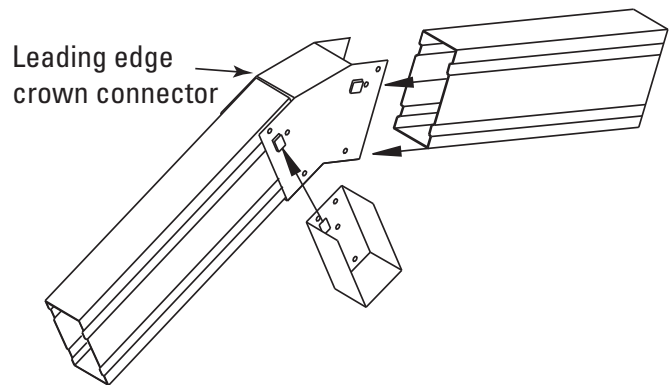

Figure 18: Crown connector assembly

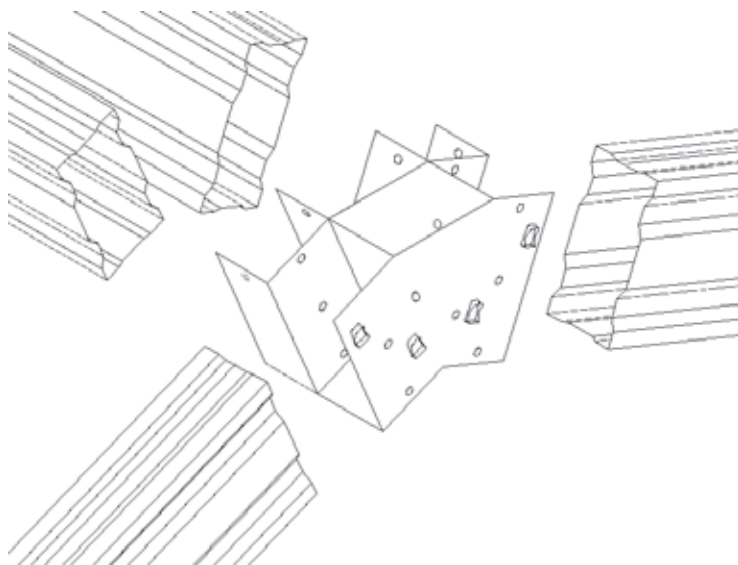

Figure 19: Exploded view of gable end truss

21. Making intermediate trusses

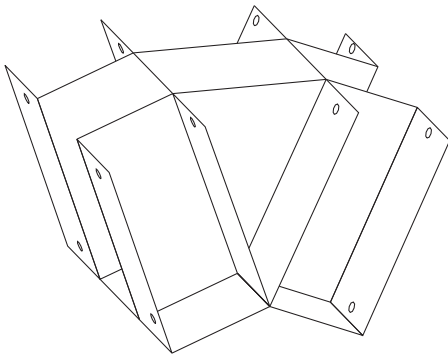

Figure 20: Intermediate crown connector

MAKING (INTERMEDIATE) TRUSS

YOU WILL NEED

RAFTERS

INTERMEDIATE CROWN CONNECTOR

PURLIN CONNECTORS

COLLAR TIE

RAIL/RAFTER CONNECTOR

FIXINGS

NOTE: PREPARE TRUSSES ON THE GROUND

From the BOM, select 2 intermediate rafters, 1 crown connector.

Feed the rafters into the connector until the top edge of the rafter is just touching the leading edge of the connector.

Make sure rafters are square to the crown connector.

Fix tek to bottom hole of each connector. Repeat 3 times.

Position the collar tie to rafter and adjust the position of the tie until it is of equal length on both sides of the rafter, maintaining your original overall measurement. Fix in position.

Temporarily fit ridge purlins from end truss to intermediate truss for bracing while completing trusses.

Find internal measurement between rails where intermediate rafter will go. With rafters fixed to crown connector, check the internal measurement from rail to rail is equal to the truss measurement as per the diagram.

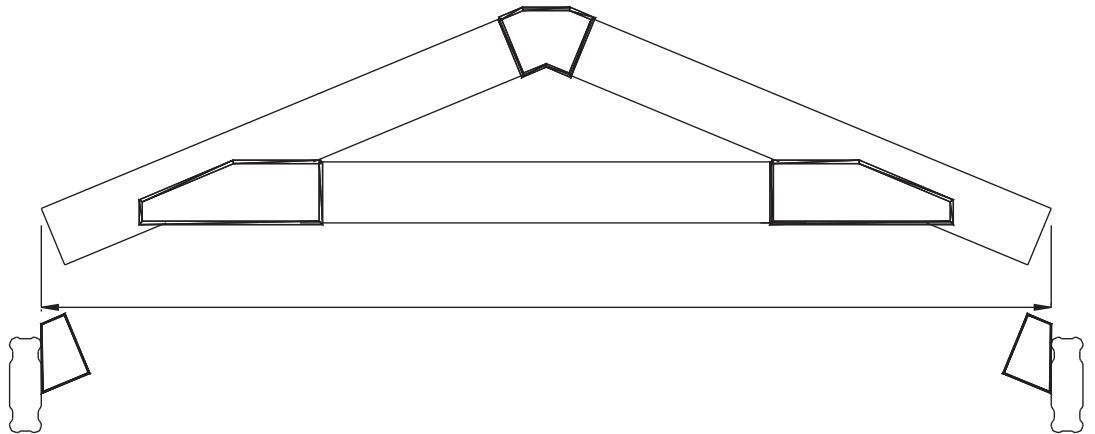

Figure 21

22. Fitting the rafter/rail connector

YOU WILL NEED

RAIL/BEAM /RAFTER CONNECTOR

FIXINGS

Before fitting truss into position, fit a rafter- rail connector to the rail.

Measure along the rail the required distance (halfway for 1 intermediate truss, 1 third distance for 2 intermediate trusses).

Fix connector at required height (See rafter rail setting dimensions).

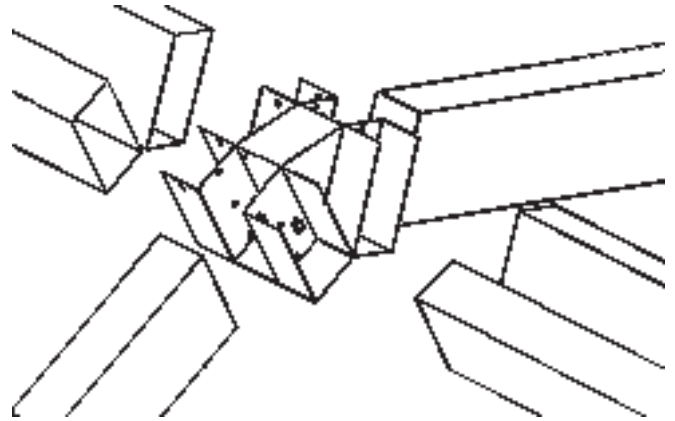

Figure 22: Rafter/ rail connector assembly

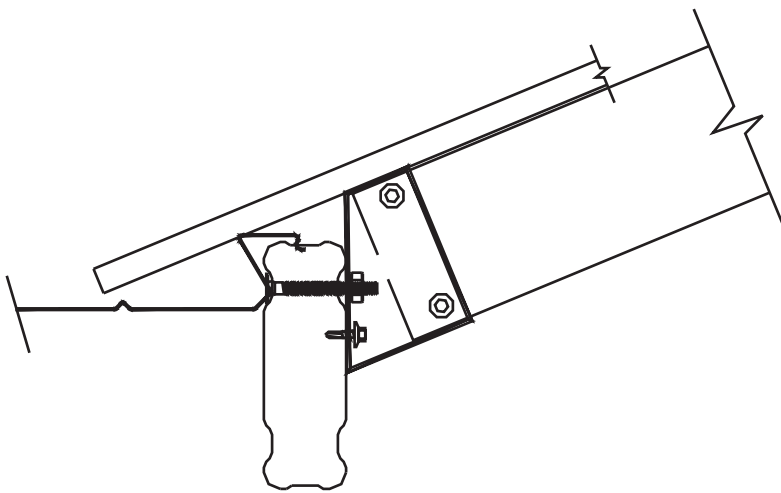
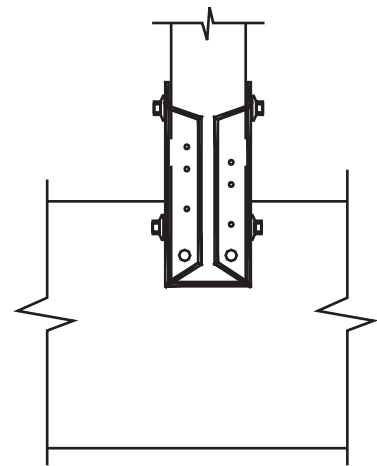

Figure 23: Fitting rafter - rail connector



23. Fitting the purlin connector

Measuring halfway up the rafter, position the purlin bracket flush with the top of the truss.

Using this last step as a template and working from top down, find measurement on remaining trusses for purlin connector and fix in position.

Repeat for other end.

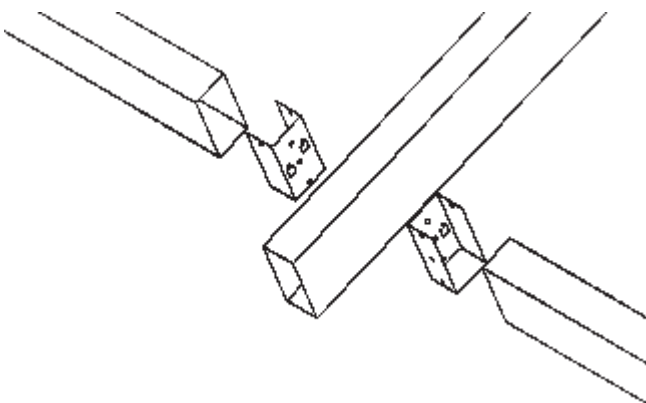

Figure 24: Gable end purlin connector

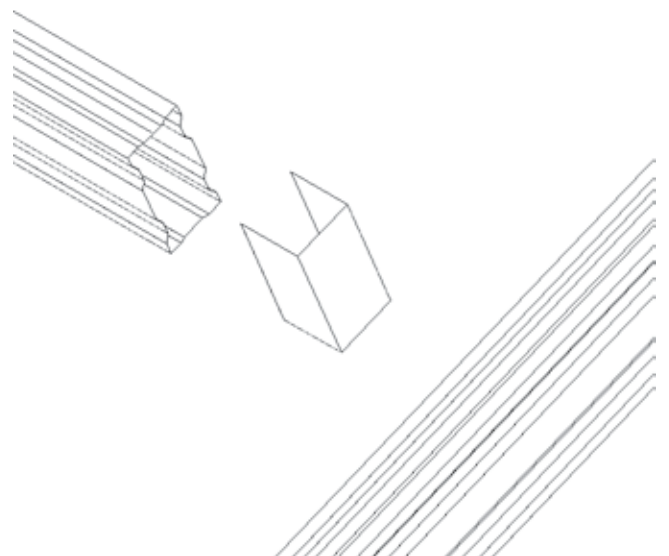

Figure 25: Intermediate truss to purlin connector

24a. Fitting FLATDEK roof sheets

- YOU WILL NEED:**
- ALUMINIUM ANGLE**
- ROOF SHEET**
- LIGHT PANEL**
- FIXINGS ROOF SHEET**
- FIXINGS LIGHT PANEL**
- FLASHINGS**

NOTE: Please read the relative drawings for fixing of roof sheets

Ready for Roof

Place and fix off remainder of purlins and find 20x12mm angle to be fixed along the top inside edge of front and rear beams/rails. This is used to hide the screws.

Seal off remaining gutters and fit flashing to junction of house and structure gutters.

Roof

- The roof sheets are precut to fit the structure.
- If your project has 3 sides open, start either end.
- Lay the sheets towards where the weather comes from.
- Start with the sheet just in from the edge of the gable end.
- Check there is approx 40mm overhang in the gutter.
- Ideally you will lay sheets towards prevailing weather.
- Position ladders so you can work safely and quickly. (Figure 26).

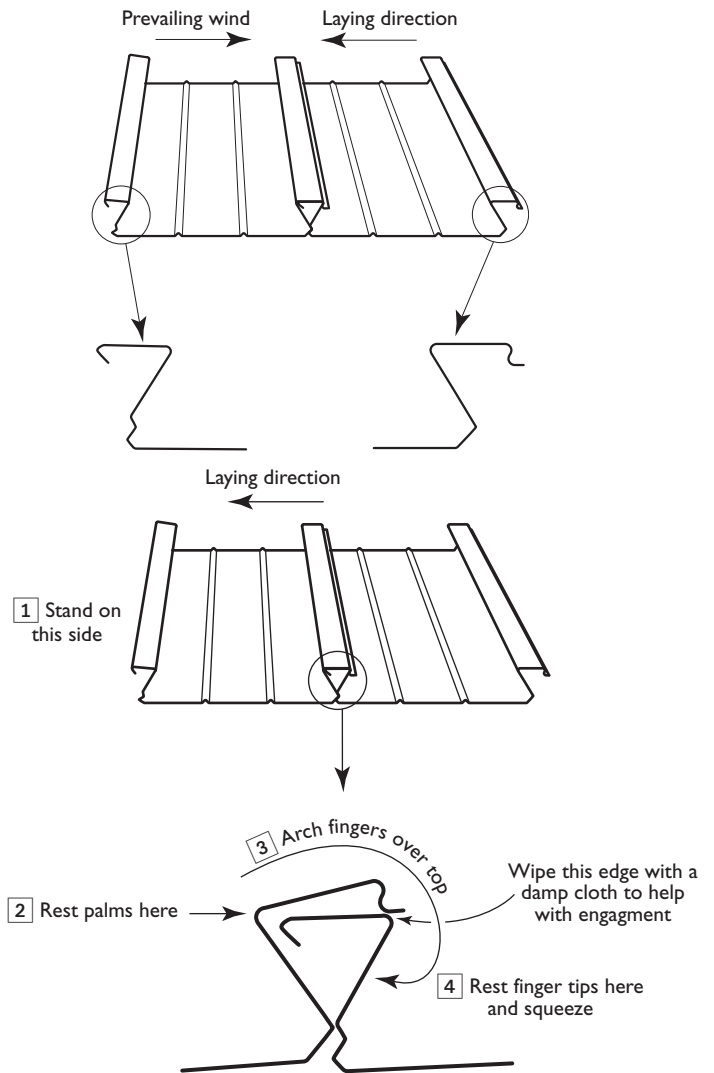

Figure 26

24b. Fitting TRIMDEK roof sheets

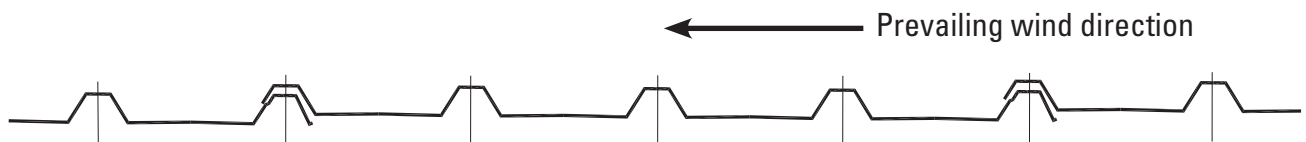

Figure 27

- First, set a string line minimum 50mm back from front edge of gutter to keep the roof sheets in line.
- Using a pair of pliers, weather the end of the roof sheets that sit against the house by bending up the bottom lip of the sheets. Be careful not to tear the corners.
- Align front edge of sheet to the string line. Check that the roof sheet is square, by measuring across to the square projection gutter at both ends of the roof sheet.
- For positioning the sheet along the projection gutter (side), fit sheet and screw through the first pan of the sheet into the gutter return lip. (Figure 27)

- Sheets should be hard into the rear attachment gutter as possible.
- Fit light panel two (2) steel sheets in from projection gutters and keep a minimum of two (2) steel sheets between panels.
- Fit light panel over top of steel sheets by two (2) crests.
- Because of its greater thermal expansion, translucent cladding should be fixed using oversized holes and sealing washers recommended by the cladding manufacturer.
- There are translucent products available that easily accommodate this. Don't exceed the maximum support spacing specified by the translucent cladding manufacturer.

25a. Fitting of TRIMDEK light panels

Fit light panel two (2) steel sheets in from projection gutters and keep a minimum of two (2) steel sheets between panels. Fit light panel over top of steel sheets by two (2) crests. (Figure 28)

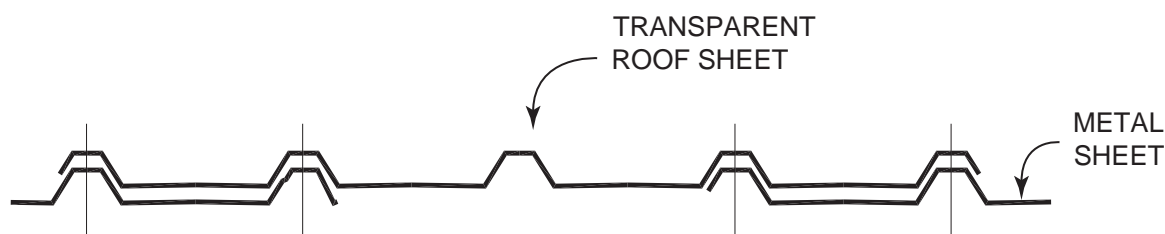

Figure 28

25b. Fitting of FLATDEK light panels

A light panel must be fitted at least 2 steel sheets in from any side and must have 2 steel sheets separating them.

Unlike the steel panels, both sides of a light panel fits over the male and female sides.

Working from a projection side, fit a minimum of 2 steel panels first and fix off.

Lay the light panel in position. Do not fix off. Next to that, place a steel sheet in under the light panel

The light panel should be sitting over the top of 2 steel sheets. Once position is correct, fix off steel sheet first and then light panel as shown below. (Figure 29)

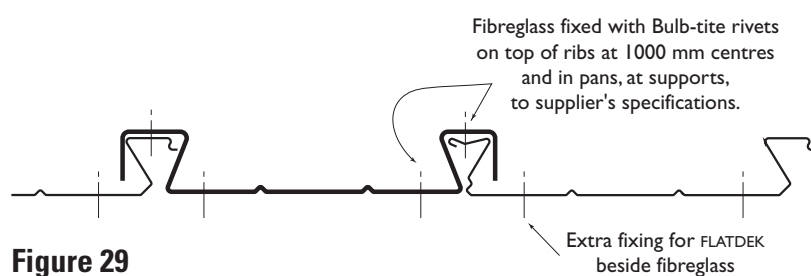

Figure 29

Roofing on insert

All roofing profiles used on the Skillion section of the structure can be used on the insert with the exception of CUSTOM ORB (RS6) (RPC6). This profile is to be used only on the insert.



Figure 30: CUSTOM ORB profile

26. Fitting of flashings

YOU WILL NEED:

4 BARGE CAPPING

1 RIDGE CAPPING

FIXINGS

26a Barge capping

Barge capping is fitted where the roofing meets the gable end and will require preparation prior to fitting.

Using a non permanent marker and a level, mark a plumb line down each end of the crown connector at the apex.

Using a sliding bevel, obtain the angle by adjusting the bevel against the vertical mark and the roof pitch.

The capping has a 110mm face and a 220 mm return.

Working from the gutter end of the capping with the 110mm side facing out, mark the plumb line. Using tin snips, cut up the face and continue the cut right across the flashing.

Working from the gutter end, sit barge cap on gable. The gutter "end stop" will prevent the capping from fitting correctly. Mark where the capping strikes the end stop and remove with tin snips.

Re-fit capping to check for fit.

At the apex, mark where the flashing and the apex meet. Remove the capping and mark the plumb line on the face of the capping. Cut up the face and continue across top of flashings.

To allow the two sides to join, a tag for fixings is to be provided on the opposite capping as in the engineering drawings. Repeat for remaining sides and fix to roof sheets with pop rivets @ 600mm ctrs.

26b. Ridge capping

With barge caps fixed in position, measure the ridge length. On the ridge flashing mark two 45 degree lines back from the centre of the flashing and cut with tin snips to outer edge.

On the other end, apply the same. Snip 10mm off each end of the flashing and carefully lift in place. If flashing came in two pieces, apply same allowing for a join in the middle of the roof.

Working from one end of the roof, position the capping 5mm from end of the barge capping. If one piece, check position of capping at ends, if two pieces, repeat same. Starting half a sheet in, fix off ridge capping using pop rivets at 600mm spacings into the nord of the sheet along the ridge purlin line. (Figure 31)

Check for straightness every meter and return to ends. To fix off at gable ends, use a non permanent marker to mark the perimeter of the ridge capping over the barge cap. Apply a bead of silicone 10mm in from this line and rivet off. Repeat for other end.

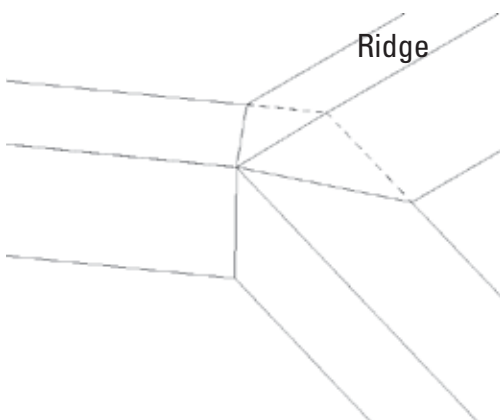

Figure 31

27. Prepare downpipes

YOU WILL NEED:

DOWNPIPE (STEEL or PVC)

OUTLET

DOWNPIPE STRAP

DOWNPIPE ELBOW

RIVETS

Place downpipe outlet on bottom side of front gutter in required position and mark internally around base.

Drill a pilot hole in bottom of gutter and then remove with snips. This can be done when preparing front gutter.

Rivet outlet to outside bottom edge of gutter where required.

Fix downpipe straps to the post with 1 rivet.

Fit supplied downpipe together using silicone to join connections.

Fix off as per CcBuilder drawings.

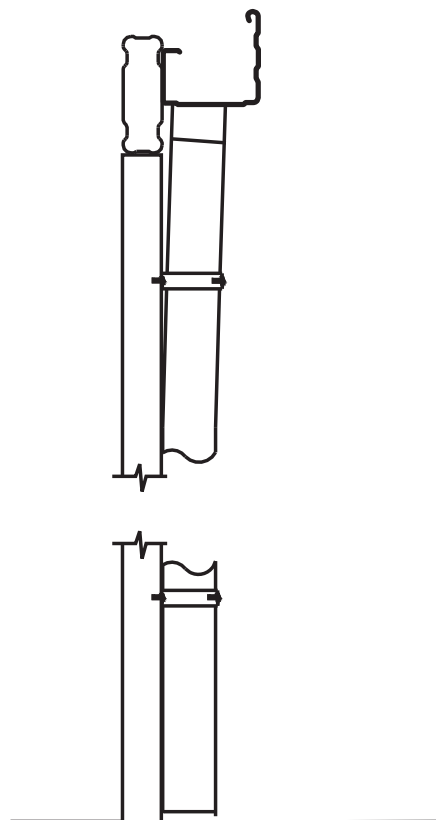

Figure 32

28 Clean up instructions

On completion remove all foreign objects from all the surfaces

e.g. Swarf (drilling debris) packaging, rubber ,etc.
Attention should be made to the rear gutter, with all foreign material hosed completely out of all gutters.
This is generally done using a hose and broom.

Please download the maintenance guide from:

www.lysaght.com

Congratulations

Your new structure is now ready to use.



Disclaimer, warranties and limitation of liability

This publication is intended to be an aid for all trades and professionals involved with specifying and installing LYSAGHT products and not to be a substitute for professional judgement.

Terms and conditions of sale available at local BlueScope Lysaght sales offices.

Except to the extent to which liability may not lawfully be excluded or limited, BlueScope Steel Limited will not be under or incur any liability to you for any direct or indirect loss or damage (including, without limitation, consequential loss or damage such as loss of profit or anticipated profit, loss of use, damage to goodwill and loss due to delay) however caused (including, without, limitation, breach of contract, negligence and/or breach of statute), which you may suffer or incur in connection with this publication.

© Copyright BlueScope Steel Limited 24 January, 2011

Discuss availability of design options with your
LYSAGHT Living Collection Dealer.

www.lysaghtlivingcollection.com

LYSAGHT Living Collection®, TRIMDEK®, FLATDEK®, COLORBOND® AND ZINCALUME® are registered trademarks of BlueScope Steel Limited, ABN 16 000 011 058. The LYSAGHT® range of products is made by or for BlueScope Steel Limited trading as BlueScope Lysaght. Lysaght Building Solutions is a wholly owned subsidiary of BlueScope Steel Limited. 24 January 2011

Colorbond®

**BLUESCOPE
LYSAGHT**

